



# ENAPART



93 S Railroad Avenue Unit C  
Bergenfield NJ 07621 USA  
[www.enapart.com](http://www.enapart.com)  
[sales@enapart.com](mailto:sales@enapart.com)



Via del Canneto 35,  
Borgosatollo, Brescia - Italia  
[www.enapart.it](http://www.enapart.it)  
[vendite@enapart.it](mailto:vendite@enapart.it)



Barbaros Mah. Ihlamur Bul. Aĝaoĝlu  
My Newwork No:3/15 Ataşehir / İstanbul  
[www.enapart.net](http://www.enapart.net)  
[satis@enapart.net](mailto:satis@enapart.net)



PRIVADA 10 B SUR #3908 COL.  
ANZUREZ, C.P. 72530, PUEBLA, PUE  
[www.enapart.com.mx](http://www.enapart.com.mx)  
[sales@enapart.com.mx](mailto:sales@enapart.com.mx)



Friedrich-Ebert-Anlage 36, 60325  
Frankfurt am Main, Germany  
[www.enapart.de](http://www.enapart.de)  
[anfrage@enapart.de](mailto:anfrage@enapart.de)



4 boulevard Carnot, 95400  
villiers-le-bel, Paris, France  
[www.enapart.fr](http://www.enapart.fr)  
[sales@enapart.fr](mailto:sales@enapart.fr)



65049, ОДЕСА, ВУЛИЦЯ ІВАНА  
ФРАНКА, БУДИНОК 55, ПОВЕРХ 3  
[www.enapart.com.ua](http://www.enapart.com.ua)  
[sales@enapart.com.ua](mailto:sales@enapart.com.ua)



MUNICIPIUL BUCUREȘTI, SECTOR 3,  
B-DUL BASARABIA, NR.250, CORP P+5  
[www.enapart.ro](http://www.enapart.ro)  
[sales@enapart.ro](mailto:sales@enapart.ro)



〒584-0023 大阪府富田林市若松町  
東2丁目2番16号  
[www.enapart.co.jp](http://www.enapart.co.jp)  
[sales@enapart.co.jp](mailto:sales@enapart.co.jp)



PLAZA NUESTRA SEÑORA DE LAS  
NIEVES 12 ,LOCAL ,50012,ZARAGOZA  
[www.enapart.es](http://www.enapart.es)  
[ventas@enapart.es](mailto:ventas@enapart.es)



Складова база „Онгъл“, Склад А2, п.к.  
4006, гр. Пловдив, България  
[www.enapart.bg](http://www.enapart.bg)  
[sales@enapart.bg](mailto:sales@enapart.bg)



3 Austin Mews, High Street, Hemel  
Hempstead, HP1 3AF , United Kingdom  
[www.enapart.co.uk](http://www.enapart.co.uk)  
[sales@enapart.co.uk](mailto:sales@enapart.co.uk)





































# Accessories



## Couplings

"A" Input Shaft End	"B" Keyway	Flexible Couplings Part No.
0.5000" - 0.5015"	0.125" x 0.062"	<b>HC30349-000</b>
0.5115" - 0.5120"	0.125 x 0.056"	<b>HC30350-000</b>
0.6250" - 0.6265"	0.094" x 0.053"	<b>HC30490-000</b>
0.6250" - 0.6265"	0.188" x 0.094"	<b>HC30351-000</b>
0.7500" - 0.7515"	0.156" x 0.078"	<b>HC30353-000</b>

Flexible Couplings are available for all shaft driven speed switches and should be used to connect the switch to the drive/input shaft to compensate for minor misalignment. Several input shaft sizes are available.

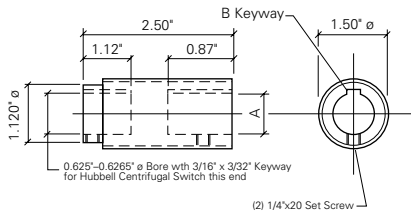

Flexible Coupling

## Separate Mounted Gear Boxes

Part No.	Gear Ratio
<b>HC65222-002</b>	2.94 To 1
<b>HC65222-001</b>	8.64 To 1

- Can be used with the 2200, 2210, 2220 switches or any other compatible devices. Shimming is necessary for use with the 2200 switches.
- Available as speed increasers or speed reducers with 2.941:1 or 8.64:1 ratios.
- Steel gears
- Designed for heavy duty use
- Flexible couplings are recommend for connecting the gear box to the drive and the speed switch.

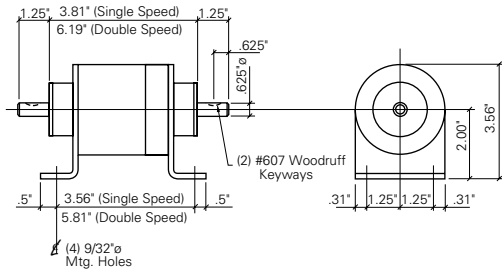

## Series 2310 Accessories

Part No.	Description
<b>HC48916-001</b>	Jam Nut (Black)
<b>HC48916-002</b>	Jam Nut (Nickel Plated)
<b>HC48943-000</b>	Mounting Bracket

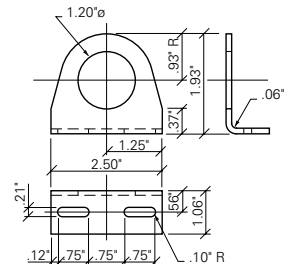
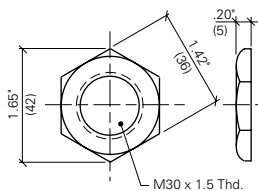

Prices for these items are located in the Accessories Section of Price List 2200/2300

# Dimensional Illustrations

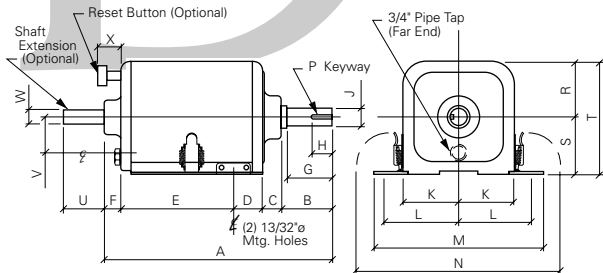

## Illustration #1

Surface Mounting Enclosure – **2200**

Approx. Weight 12 lbs.

NEMA 1 Gasketed or NEMA 3R

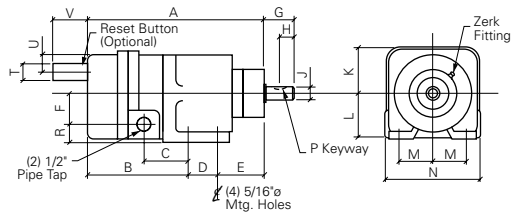

## Illustration #3

Surface Mounting Enclosure – **2210/2220**

Approx. Weight 4 lbs.

NEMA 4 or 13

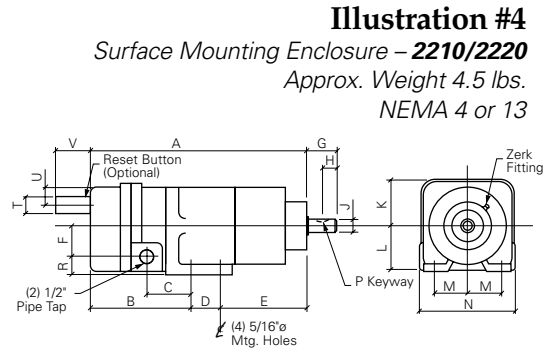

## Illustration #4

Surface Mounting Enclosure – **2210/2220**

Approx. Weight 4.5 lbs.

NEMA 4 or 13

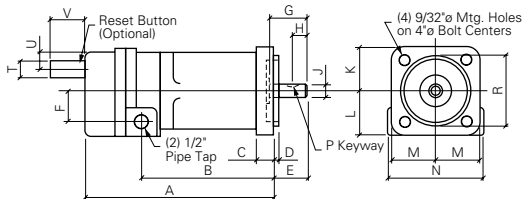

## Illustration #5

Flange Mounting Enclosure – **2210/2220**

Approx. Weight 5 lbs.

NEMA 13

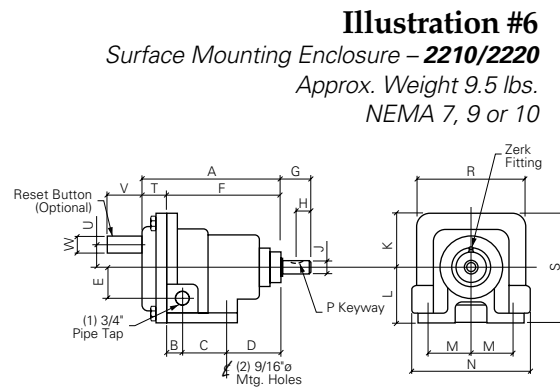

## Illustration #6

Surface Mounting Enclosure – **2210/2220**

Approx. Weight 9.5 lbs.

NEMA 7, 9 or 10

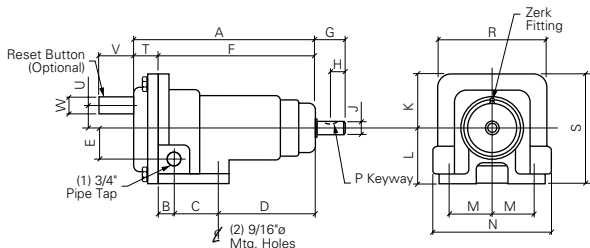

## Illustration #7

Surface Mounting Enclosure – **2210/2220**

Approx. Weight 11.5 lbs.

NEMA 7 or 9 with Speed Inserter

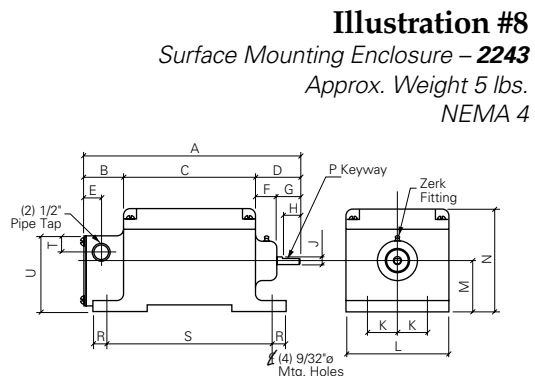

## Illustration #8

Surface Mounting Enclosure – **2243**

Approx. Weight 5 lbs.

NEMA 4

See page 20 & 21 for dimensions.

### Illustration #9

Surface Mounting Enclosure – **2260**  
 Approx. Weight 4 lbs.  
 NEMA 13

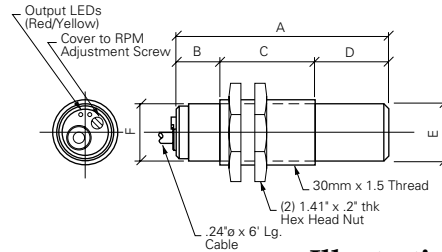
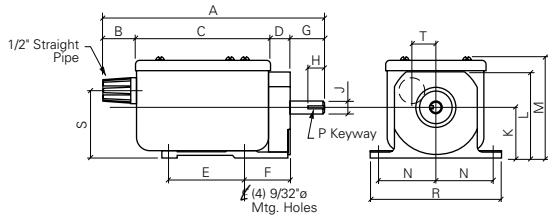

### Illustration #10

Surface Mounting Enclosure – **2310**  
 Approx. Weight 1 lbs.  
 NEMA 4X or 13

### Illustration #11

Flange Mounting Enclosure – **2210/2220**  
 Approx. Weight 11.5 lbs.  
 NEMA 7 or 9

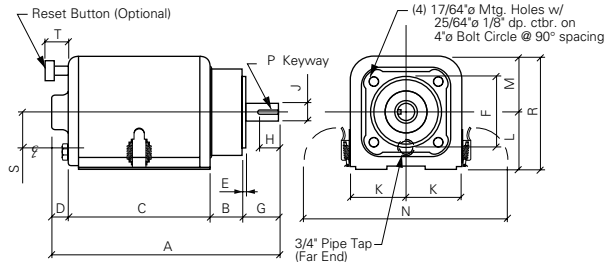
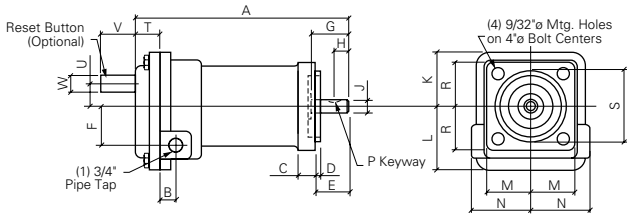

### Illustration #12

Flange Mounting Enclosure – **2200**  
 Approx. Weight 13.5 lbs.  
 NEMA 1 Gasketed

### Illustration #13

Surface Mounting Enclosure – **2210/2220**  
 Approx. Weight 5.5 lbs.  
 NEMA 4 or 13

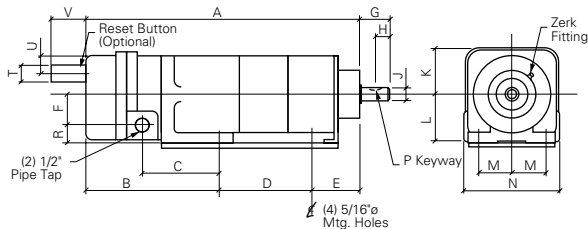

#### Notes:

For pages 18 – 21

1. All dimensions are in inches unless noted otherwise. Available options titles are "Res But" – Reset Button, "Sft Ext" – Shaft Extension, "Zrk Fit" – Zerk Fitting and "Cond Con" – Conduit Connection and Lock Screw.
2. The notes listed below are for size of conduit connection supplied on speed switches and appear on the tables on pages 20 & 21.
  - (1) 1-1/8" x 12NF Thread .... 1/2" Ent.
  - (2) 1" x 14NF Thread ..... 7/16" Ent.
  - (3) 1-1/8" x 12NF Thread .... 5/8" Ent.
  - (4) 1-1/8" x 12NF Thread ..... 3/4" Ent.



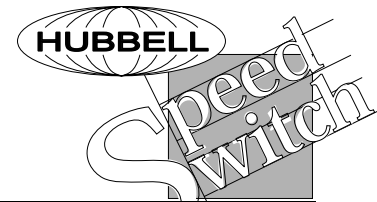

See page 19 for notes. See page 18 & 19 for illustrations.

M	N	P	Dimensions							Res But	Sft Ext	Zrk Fit	Cond Con	Part Number
			R	S	T	U	V	W	X					
—	8.75	3/16" x 3/32"	2.50	2.75	5.25	—	1.56	—	—					PRx-xxx-xx
—	8.75	3/16" x 3/32"	2.50	2.75	5.25	1.25	1.56	0.39	—		✓			-xxx-xxE
2.50	8.75	3/16" x 3/32"	5.25	1.56	—	—	—	—	—					-xxx-xxF
7.13	8.75	3/16" x 3/32"	2.50	2.75	5.25	—	1.56	—	—					-xxx-xxWP
—	8.75	3/16" x 3/32"	2.50	2.75	5.25	—	1.56	—	1.25	✓				PRS-038M-xx
—	8.75	3/16" x 3/32"	2.50	2.75	5.25	1.25	1.56	0.39	1.25	✓	✓			-038M-xxE
2.50	8.75	3/16" x 3/32"	5.25	1.56	1.13	—	—	—	—	✓				-038M-xxF
1.25	4.44	#607 Wood.	0.69	—	—	—	—	—	—			✓		2210-xxxxx4
1.25	4.44	#607 Wood.	0.69	—	—	—	—	—	—			✓		-xxxxx4S
1.25	4.44	#607 Wood.	0.69	—	—	—	—	—	—			✓		-xxxxx4SS
1.25	4.44	#607 Wood.	0.69	—	1.00	1.31	1.81	—	—	✓		✓		-xx2xx4M
1.25	4.44	#607 Wood.	0.69	—	1.00	1.31	1.81	—	—	✓		✓		-xx2xx4SM
1.25	4.44	#607 Wood.	0.69	—	1.00	1.31	1.81	—	—	✓		✓		-xx2xx4SSM
2.13	6.13	#607 Wood.	5.38	5.75	1.44	—	—	—	—					-xxxxx7
2.13	6.13	#607 Wood.	5.38	5.75	1.44	—	—	—	—					-xxxxx7S
1.88	3.06	#607 Wood.	1.88	3.00	1.44	—	—	—	—					-xxxxx7F
2.13	6.13	#607 Wood.	5.38	5.75	1.44	1.88	1.81	1.00	—	✓				-xx2xx7M
1.88	3.06	#607 Wood.	1.88	3.00	1.44	1.88	1.81	1.00	—	✓				-xx2xx7FM
2.13	6.13	#607 Wood.	5.38	5.75	1.44	1.88	1.81	1.00	—	✓				-xx2xx7SM
2.13	6.13	#607 Wood.	5.38	5.75	1.44	—	—	—	—			✓		-xxxxx9
2.13	6.13	#607 Wood.	5.38	5.75	1.44	—	—	—	—			✓		-xxxxx9S
1.88	3.06	#607 Wood.	1.88	3.00	1.44	—	—	—	—					-xxxxx9F
2.13	6.13	#607 Wood.	5.38	5.75	1.44	1.88	1.81	1.00	—	✓		✓		-xx2xx9M
1.88	3.06	#607 Wood.	1.88	3.00	1.44	1.88	1.81	1.00	—	✓				-xx2xx9FM
2.13	6.13	#607 Wood.	5.38	5.75	1.44	1.88	1.81	1.00	—	✓		✓		-xx2xx9SM
2.13	6.13	#607 Wood.	5.38	5.75	1.56	—	—	—	—			✓		-xxxxx10
2.13	6.13	#607 Wood.	5.38	5.75	1.56	—	—	—	—			✓		-xxxxx10S
1.25	4.44	#607 Wood.	0.69	—	—	—	—	—	—					-xxxxx13
1.88	4.44	#607 Wood.	3.00	—	—	—	—	—	—					-xxxxx13F
1.88	4.44	#607 Wood.	3.00	—	—	—	—	—	—					-xxxxx13FS
1.25	4.44	#607 Wood.	0.69	—	—	—	—	—	—					-xxxxx13S
1.25	4.44	#607 Wood.	0.69	—	—	—	—	—	—					-xxxxx13SS
1.25	4.44	#607 Wood.	0.69	—	1.00	1.31	1.81	—	—	✓				-xx2xx13M
1.88	4.44	#607 Wood.	3.00	—	1.00	1.31	1.81	—	—	✓				-xx2xx13FM
1.88	4.44	#607 Wood.	3.00	—	1.00	1.31	1.81	—	—	✓				-xx2xx13FSM
1.25	4.44	#607 Wood.	0.69	—	1.00	1.31	1.81	—	—	✓				-xx2xx13SM
1.25	4.44	#607 Wood.	0.69	—	1.00	1.31	1.81	—	—	✓				-xx2xx13SM
1.25	4.44	#607 Wood.	0.69	—	—	—	—	—	—			✓		2220-xxxxx4
1.25	4.44	#607 Wood.	0.69	—	—	—	—	—	—			✓		-xxxxx4S
1.25	4.44	#607 Wood.	0.69	—	—	—	—	—	—			✓		-xxxxx4SS
2.13	6.13	#607 Wood.	5.38	5.75	1.56	—	—	—	—					-xxxxx7
2.13	6.13	#607 Wood.	5.38	5.75	1.56	—	—	—	—					-xxxxx7S
1.88	3.06	#607 Wood.	1.88	3.00	1.44	—	—	—	—					-xxxxx7F
2.13	6.13	#607 Wood.	5.38	5.75	1.56	—	—	—	—			✓		-xxxxx9
2.13	6.13	#607 Wood.	5.38	5.75	1.56	—	—	—	—			✓		-xxxxx9S
1.88	3.06	#607 Wood.	1.88	3.00	1.44	—	—	—	—					-xxxxx9F
1.25	4.44	#607 Wood.	0.69	—	—	—	—	—	—					-xxxxx13
1.88	4.44	#607 Wood.	3.00	—	—	—	—	—	—					-xxxxx13F
1.88	4.44	#607 Wood.	3.00	—	—	—	—	—	—					-xxxxx13FS
1.25	4.44	#607 Wood.	0.69	—	—	—	—	—	—					-xxxxx13S
1.25	4.44	#607 Wood.	0.69	—	—	—	—	—	—					-xxxxx13SS
2.00	4.31	1/32" Flat	0.38	6.63	0.88	3.19	—	—	—					Series 2243
4.10	2.34	3/16" sq.	5.19	2.75	0.85	—	—	—	—					Series 2260
—	—	—	—	—	—	—	—	—	—					Series 2310

NOTE: Dimensions are approximate. Contact factory for official outline drawings.

# Miscellaneous Information

## Series 2200

### Enclosure

The frame and end plate are cast iron, accurately machined and provided with sealed and permanently lubricated precision ball bearings in which the shaft rotates. The steel shaft is hardened and ground for extreme accuracy and carries the flyweight and contact actuation assembly. Lateral motion of the flyweights is transmitted to the contact actuation assembly through a sealed and permanently lubricated precision thrust ball bearing.

The heavy gauge sheet steel cover is provided with a gasket to make the enclosure semi-dust tight and oil resistant. NEMA Type 1 Gasketed. The cover is secured to the frame by means of two spring latches which keep the gasket under pressure at all times but yet the cover can be removed easily without the use of tools.

### Contacts

The contact compartment provides several basic contact arrangements as required for various applications. Slow-action butt type bridging contacts for rapid speed change conditions or snap-action precision contacts for slow speed changes can be supplied.

Type PRS-031 is equipped with single pole double throw snap action contacts from which one normally open and one normally closed contact with common feed are available. At the point of contact actuation, the normally open contact closes and the normally closed contact opens on ascending speed and visa versa on descending speed.

Type PRD-031 is equipped with two snap action contacts designed for use on DC control circuits since the contacts are equipped with a permanent magnet blowout and are provided with one normally open and one normally closed contact. The contacts of this switch are suitable for operation at 250 volts DC maximum.

## Series 2210

### Enclosure

Standard Type C centrifugal switch housings are molded of tough fiberglass reinforced polyester resin, for the flyweight compartment, and a cast aluminum housing for the contact compartment. The standard molded housings are resistant to most acid, alkali and salt compounds.

When flange-mounting is specified, the flange and the flyweight section of the housing are precisely machined from a single aluminum casting.

NEMA Type 4 enclosures (watertight) for indoor/outdoor applications are furnished with a double shaft seal & grease fitting for lubrication and purging ensuring longer bearing life.

NEMA Type 8, 9 and 10 explosion proof enclosures are available also. These enclosures have precisely machined cast aluminum housings, either for surface or flange mounting.

### Speed Adjustment

Speed points at which contacts operate are easily adjustable in the field within the standard operating ranges. Switches are factory set at minimum ascending speeds as listed. Other contact settings may be specified as an option. Each set of snap-action or slow-action contacts is independently adjustable from the rear while the switch is rotating. Also the speed setting of both sets of contacts can be changed at the same time by varying the tension on the main adjustment spring with the adjustment nut.

### Contacts

The contact compartment provides several basic contact arrangements as required for various applications. Either slow-action butt-type bridging contacts for rapid speed-change conditions, or snap-action contacts, for slow speed changes, can be provided.

One set or two sets of normally open and/or normally closed single-throw contacts – each set independently adjustable – are available in the slow-action type. One set or two sets of normally open and normally closed single-pole, double-throw, snap-action switches are also available, with each set independently adjustable.

These two separate sets of contacts can be adjusted for operation at different speeds so that two separate operations can be controlled from one speed sensing switch. Therefore, it is possible to perform separate functions at two different speeds. A directional sensing form of the switch employs slow-action butt-type bridging contacts in normally open position only.

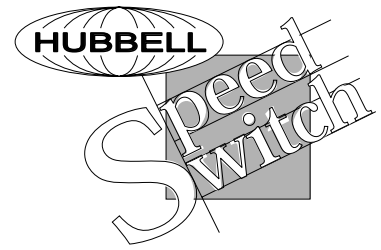

## Series 2220

### Enclosure

The Type F fluid switch is supplied in a NEMA 13 industrial enclosure to resist lint, dust, seepage, external condensation and spraying of water, oil or coolant. For outdoor or indoor applications susceptible to splashing, or direct water spray, select a NEMA 4 enclosure. For hazardous locations containing explosive gas, NEMA 7, Class I, Group D should be used. NEMA 9, Class II, Group E, F, or G enclosures should be used in hazardous locations containing explosive dust. This design incorporates a double shaft seal to exclude dust particles from the switch interior.

This switch housing is a two part unit, fitted precisely together with tightly gasket joints. The front section encloses the fluid drag assembly and is molded of tough glass fiber reinforced polyester resin. The rear section, which encloses the contact-making compartment, is of cast aluminum. Both housings have ample cross-section to provide very rugged enclosures capable of withstanding shock impact or fracture due to severe service conditions. The aluminum housing is equipped with a grounding screw which provides a means of grounding the shaft to the conduit.

### Speed Adjustment

Speed points at which contacts operate are easily adjustable in the field. Switches are factory-set at minimum rpm, but other contact settings may be specified as an option. Type F fluid switch contacts are easily and independently adjustable while running, to compensate for any contact operating variance due to ambient temperature conditions.

The contact compartment houses two single-pole double-throw snap-action switches. Both switches can be factory-assembled to operate in same direction, or one for each direction.

## Series 2243

The output of the unit is provided by a single pole double throw plug-in type relay. The relay is located in the forward compartment. The relay contacts are factory wired to the terminal block in the rear compartment for easy customer connections.

On units designated for overspeed application, the relay de-energizes when set point is attained. On units designated for underspeed application, the relay de-energizes when set point is attained. The differential between ascending and descending set points is easily adjusted.

Type D Speed Responsive Switches are designed for reliable operation. In the event of component failure, the output relay reverts to a de-energized position. Long life and high reliability has been designed into these devices through the use of proven integrated circuits, transient voltage protection networks and high quality components. Silicon solid state components are used throughout to assure reliable operation over a wide temperature range.

To represent their durability, these switches are used successfully on automotive punch press applications.

### Enclosure

The standard surface mounted enclosure is cast aluminum and is suitable for NEMA and CEMA Type 4.

The main compartment houses and shields the speed adjustment potentiometers, the "light chopping disc" and the chassis. The rear compartment contains the terminals for the input power and output relay connections. Covers for both compartments are provided with gaskets.

The Type D switch is available with either a  $\frac{3}{8}$ " diameter shaft which has a flat for set screw securing, or a  $\frac{5}{8}$ " diameter shaft which is supplied with a  $\frac{3}{16}$ " square key. The shaft is supported by two large, lifetime-lubricated ball bearings for long life and low driving torque.

A grease fitting and double shaft seals are provided. Application of lubricant purges the area between the seals and prevents the penetration of water and abrasive dust.

## Series 2260

The Type E Switch is a unitized device containing heavy duty industrial types of sub-modules required to provide consistent, precise, and repetitively accurate response.

The stainless steel input shaft is supported in the enclosure by two permanently sealed and lubricated ball bearings.

### Speed Adjustment

The speed point at which the contacts operate is easily adjustable within the standard 3-300 rpm adjustment range. Clockwise rotation of the adjustment pot increases setting, counterclockwise rotation of the adjustment pot decreases setting.

All Type E units are factory set at the minimum ascending trip speed, 3 rpm, unless a specific setting is requested.

## Series 2310

The Series 2310 speed responsive switches are available in both 3-wire low DC voltage and 2-wire series load activating AC voltage. Three (3) wire DC units operate either normally closed or normally open transistor outputs that can be either NPN "load sinking" or PNP "load sourcing" versions. All ver-



# Miscellaneous Information

sions of these switches are available in a plastic threaded housing or in a plastic housing with a nickel-plated brass threaded sleeve.

Easily recalibrated for "home" position, the Series 2310 permits easy resetting to compensate for belt stretching or slipping on conveyor applications, and for compensatory adjustments on variable speed operations.

In order to sense slower speeds outside the listed ranges, multiple events or actuations per revolution must be used.

## Series 2310 Setpoint Selection

The Series 2310 speed adjustment ranges are shown in the graph below. The switch is settable on location with just a small screwdriver which is provided. The chart below left shows speed ranges based on single event measurements using a standard target. The speed range is directly related to the sensitivity of

Select a mounting area, keeping the Free Zone requirements of non-shielded proximity sensors in mind (see below). The target must move laterally across the face of the speed switch. Actuating distance from the target to the speed switch face is shown in the adjacent figure and table. This information provides an estimated setup distance prior to actual starting.

The speed setting within a given sensor's range is adjustable with the 20-turn RPM adjustment potentiometer located behind the access screw. The ideal location of the speed switch is midway within this operating range.

the switch, lateral motion and the material being sampled.

The chart below right shows the effect of lateral motion to the sensing range. Several representative factors for different materials are shown on the bottom right.

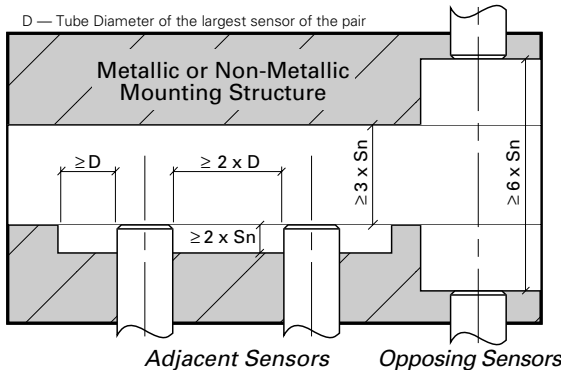
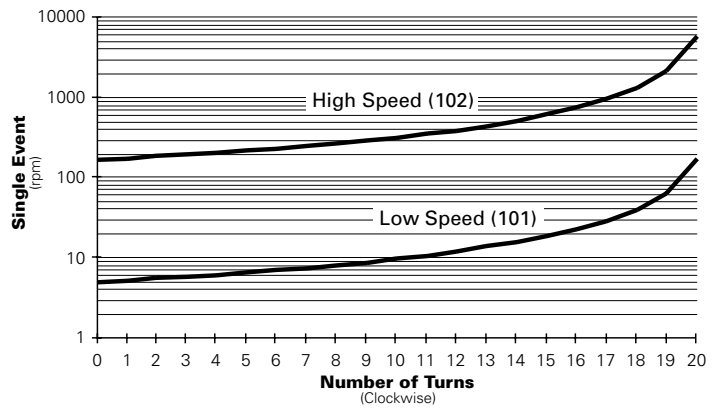
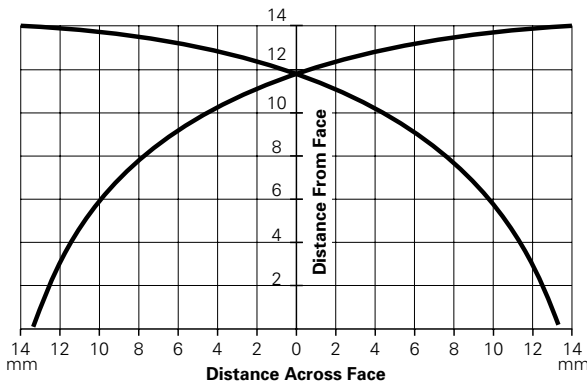

## Material Reduction Factors

Based on a 30mm x 30mm x 1.5mm target

Steel .....	1.0
Stainless Steel .....	0.7 – 0.8
Aluminum .....	0.3 – 0.5
Brass .....	0.3 – 0.4
Copper .....	0.3 – 0.4



hubbell industrial controls, inc.

**Hubbell Industrial Controls, Inc.**

a subsidiary of Hubbell Incorporated  
 4301 Cheyenne Drive, Archdale, NC 27263  
 Phone (336) 434-2800 · Fax (336) 434-2803  
[www.hubbell-icd.com](http://www.hubbell-icd.com)  
[sales@hubbell-icd.com](mailto:sales@hubbell-icd.com)