

Documentation

RM-V16 Filter control and I/O module

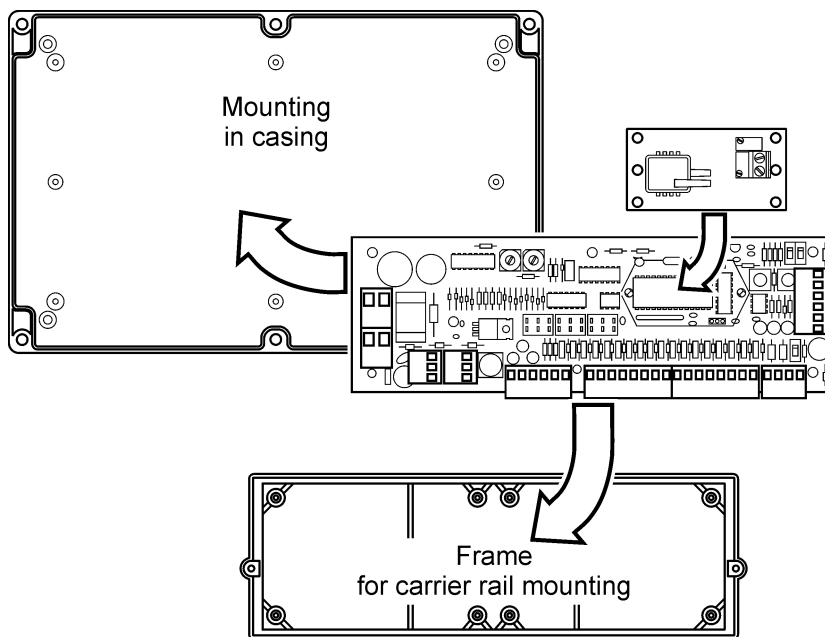

Table of Contents

| | | |
|-----|----------------------------------|----|
| 1 | Equipment specification | 3 |
| 2 | Electrical Connections | 4 |
| 3 | Settings | 7 |
| 3.1 | In standalone mode..... | 7 |
| 3.2 | In <i>R-IMC</i> Bus mode..... | 7 |
| 4 | Casing and assembly holders..... | 8 |
| 4.1 | Sealed casing..... | 8 |
| 4.2 | Assembly holders..... | 8 |
| 5 | Technical data..... | 9 |
| 6 | Scale drawings..... | 10 |

Regulations

| |
|--|
| EN 60.204 part 1 2014/30/EU 2014/35/EU |
|--|

Legend



Important note



Important warning

Safety instructions

Device failure, serious or even fatal injuries may occur as a result of improper installation of the *RM-V16* or connected equipment. Therefore, in addition to the general safety regulations for equipment in industrial electrical installations, carefully observe the points set out below:

- Installation of the *RM-V16* may be carried out only by qualified experts, in accordance with the provisions of IEC 364, DIN VDE 0105 for electrical equipment.
- Regarding the installation site, all applicable laws, rules and regulations governing the installation of electrical equipment must be observed.
- Devices with protection degree IP00 without covers may only be adjusted by authorised experts, when disconnected, and whilst observing the local safety and accident prevention regulations.
- The *RM-V16* may only be operated in the permitted operating area.



Switch off the mains supply before replacing the *RM-V16* or any components connected to it. Failure to do so could damage the device.

1 Equipment specification

The *RM-V16* can be used as a standalone filter controller or as an I/O module in the *R-IMC BUS* system. Standalone or *R-IMC-Bus* mode is selected using the S3 selector switch on the *RM-V16* board (see Figure 1). In the ON position, the *RM-V16* works as a standalone filter controller, in the 1 position it works as an I/O module for a higher-level control device (*RM-300 C*, *RM-400 C* or *RM-1000 C*).

i Standalone or *R-IMC-Bus* mode is selected using the S3 selector switch on the *RM-V16* board.

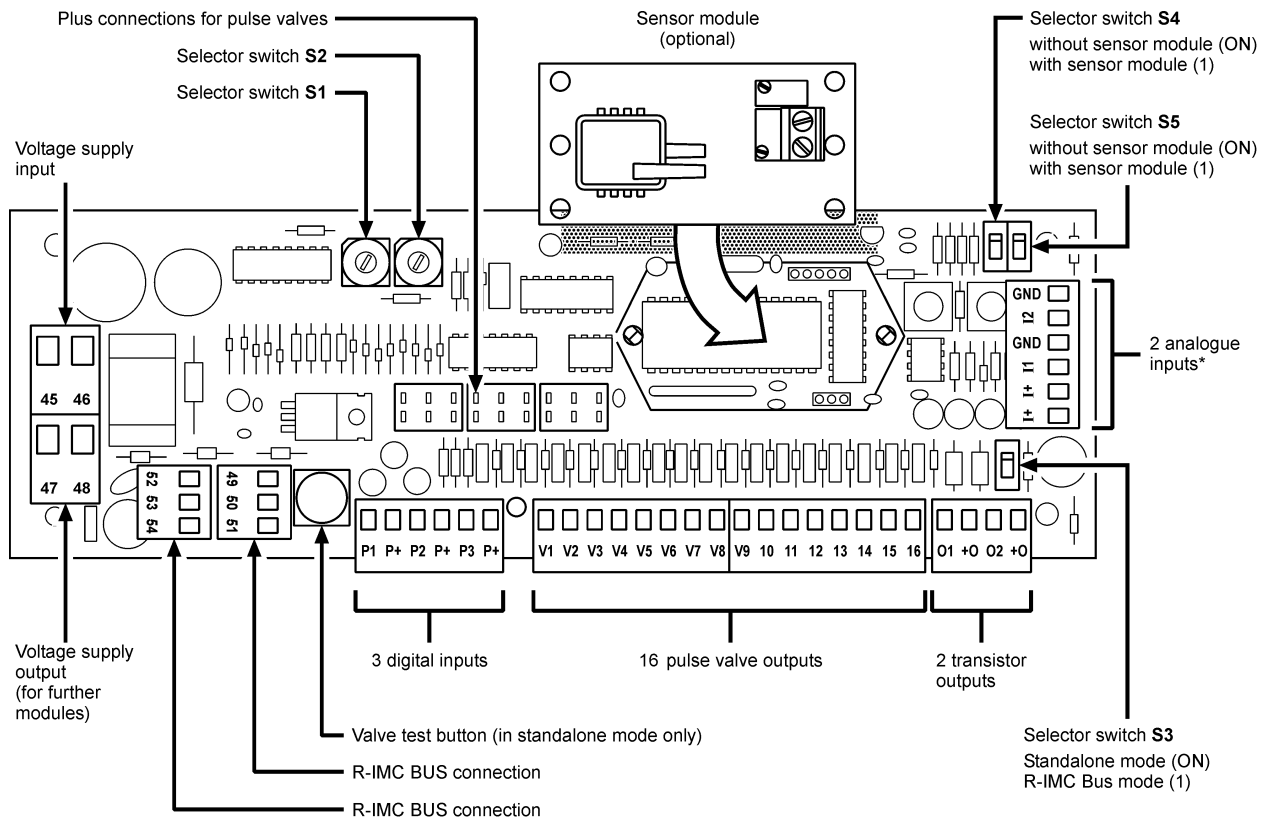

* If a sensor module is fitted, only one input is available.

Figure 1: Layout of the *RM-V16* board

If the *RM-V16* is used to measure differential pressure, a sensor module (optional) is plugged into the prepared slot using distance holders (see Figure 1). The selector switches S4 and S5 must also be switched to the 1 position.

i An optional sensor module is required for differential pressure measurement.

2 Electrical Connections

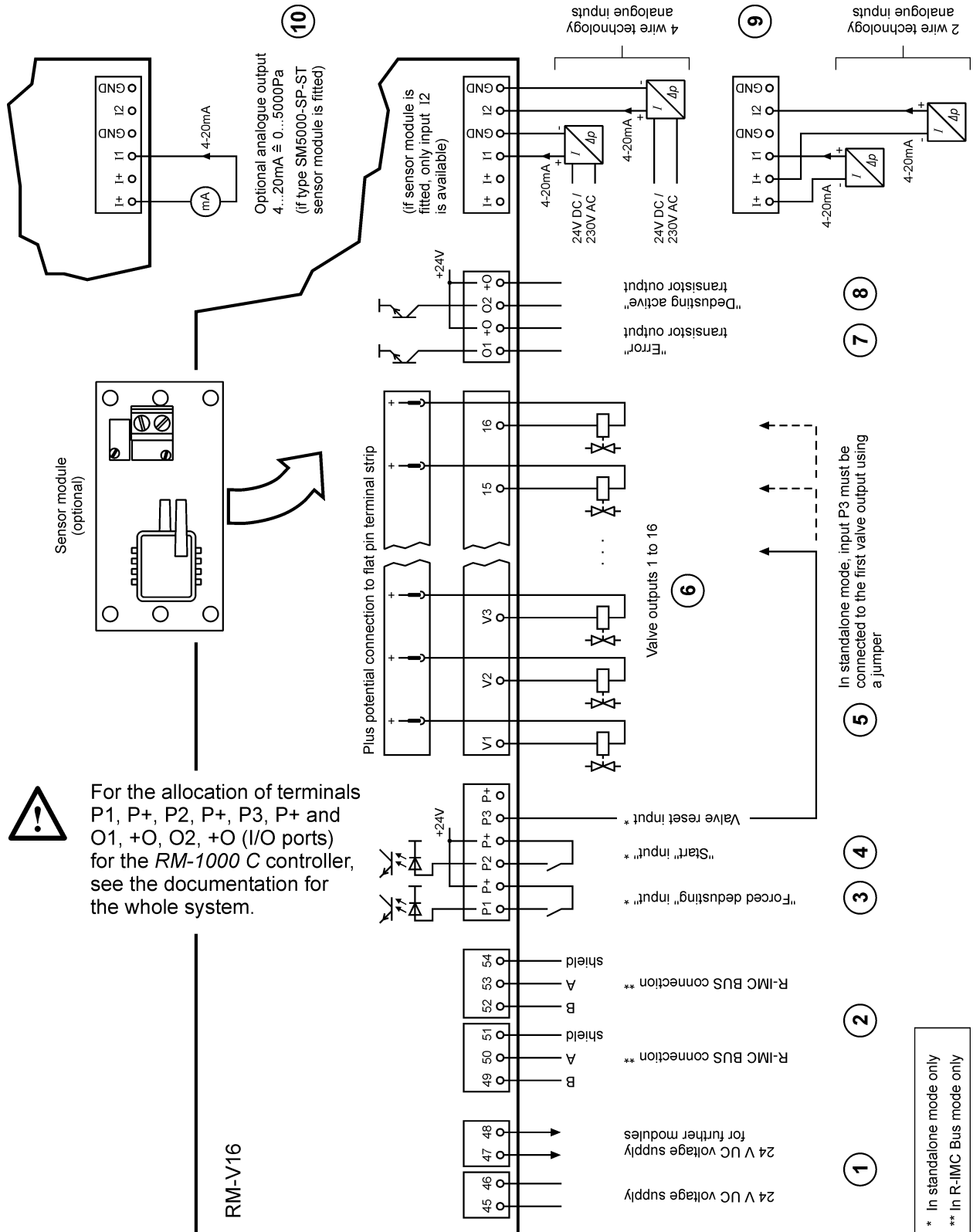

Figure 2: Wiring diagram for the RM-V16

| No. in Figure 2 | Description | Standalone mode | R-IMC Bus mode |
|-----------------|---|-----------------|----------------|
| ① | Voltage supply 24V DC / 24 V AC Terminals 47 and 48 are used to supply further modules. | ☒ | ☒ |
| ② | R-IMC BUS connection Terminals 49 (B), 50 (A), 51 (shield) and 52 (B), 53 (A), 54 (shield) | ☐ | ☒ |
| ③ | “Forced dedusting” input A potential-free contact is attached to terminals P1 and P+ to activate forced dedusting. If the contact closes, the connected valves are activated with the set pulse time and a fixed pause time of 5 seconds. When the contact is opened, forced dedusting is switched off. Dedusting begins with the valve following the last one activated. | ☒ | ☐ |
| ④ | “Start” input A potential-free contact is attached to terminals P2 and P+ to activate dedusting. If the contact closes, the connected valves are activated in sequence with the set pulse and pause times. When the contact is open, dedusting is switched off. Dedusting begins with the valve following the last one activated. | ☒ | ☐ |
| ⑤ | Valve reset input If fewer than 16 solenoid valves are connected to the <i>RM-V16</i> in standalone mode, terminal P3 must be connected to the first unused valve output using a jumper. If terminals P3 and GND are bridged in <i>R-IMC</i> bus mode, valve outputs 1 to 16 will be inactive. | ☒ | ☐ |
| ⑥ | Valve outputs Up to 16 solenoid valves with a measured voltage of 24 V DC can be connected to terminals V1, V2, V3, ..., V9, 10, 11, 16 (minus potential). The plus potential is connected to the flat pin terminal strip on the board using flat pin terminals. | ☒ | ☒ |
| ⑦ | Transistor output “Error” If the unit is operating normally, there is a 24 V DC signal on terminals O1 and +O. As soon as an error occurs, the output has a 0 V DC signal. The error message is reset every time dedusting starts. | ☒ | ☐ |
| ⑧ | Transistor output “Dedusting active” Terminals O2 and +O carry a 24 V DC signal when a dedusting process is running (even during forced dedusting). If no dedusting is taking place, the output has a 0 V DC signal. | ☒ | ☐ |

| No. in Figure 2 | Description | Standalone mode | R-IMC Bus mode |
|-----------------|---|--------------------------|-------------------------------------|
| 9 | <p>Analogue inputs</p> <p>If no sensor module is fitted, two analogue inputs are available. Figure 2 shows the allocation of terminals using the example of the connection of two differential pressure sensors using 4-wire and 2-wire technology. If a sensor module is fitted, the first analogue input is allocated.</p> | <input type="checkbox"/> | <input checked="" type="checkbox"/> |
| 10 | <p>Analogue 4-20 mA outputs</p> <p>If a type SM5000-SP-ST sensor module is plugged into the board of the <i>RM-V16</i> and the selector switch S4 is set to the 1 position, there is a 4 ... 20 mA output, corresponding to 0 ... 5000 Pa, on terminals I+ and I1 (see also Figure 1).</p> | <input type="checkbox"/> | <input checked="" type="checkbox"/> |

3 Settings

3.1 In standalone mode

In standalone mode, the pulse time is set on selector switch S1 and the pause time for the dedusting pulses is set on selector switch S2 in accordance with the following two tables (see also Figure 1).

Setting the pulse time (selector switch S1)

| S1 setting | Pulse time |
|------------|------------|
| 0 | 50 ms |
| 1 | 60 ms |
| 2 | 70 ms |
| 3 | 80 ms |
| 4 | 90 ms |
| 5 | 100 ms |

| S1 setting | Pulse time |
|------------|------------|
| 6 | 120 ms |
| 7 | 140 ms |
| 8 | 160 ms |
| 9 | 180 ms |
| A | 200 ms |
| B | 220 ms |

| S1 setting | Pulse time |
|------------|------------|
| C | 250 ms |
| D | 300 ms |
| E | 400 ms |
| F | 500 ms |
| | |

Setting the pause time (selector switch S2)

| S2 setting | Pause time |
|------------|------------|
| 0 | 2 s |
| 1 | 3 s |
| 2 | 4 s |
| 3 | 5 s |
| 4 | 6 s |
| 5 | 8 s |

| S2 setting | Pause time |
|------------|------------|
| 6 | 10 s |
| 7 | 12 s |
| 8 | 16 s |
| 9 | 20 s |
| A | 25 s |
| B | 30 s |

| S2 setting | Pause time |
|------------|------------|
| C | 40 s |
| D | 55 s |
| E | 80 s |
| F | 120 s |
| | |

3.2 In R-IMC Bus mode

In *R-IMC bus* mode, the bus address is set on selector switch S1 and the number of connected valves is set on selector switch S2 in accordance with the following two tables (see also Figure 1).

Setting the I/O module number (selector switch S1)

| S1 setting | I/O module no. | |
|------------|--------------------|----------|
| | RM-300C RM-400C | RM-1000C |
| 0 | – | – |
| 1 | 1 | – |
| 2 | 2 | 1 |
| 3 | 3 | 2 |
| 4 | 4 | 3 |
| 5 | 5 | 4 |

| S1 setting | I/O module no. | |
|------------|--------------------|----------|
| | RM-300C RM-400C | RM-1000C |
| 6 | 6 | 5 |
| 7 | 7 | 6 |
| 8 | 8 | 7 |
| 9 | 9 | 8 |
| A | 10 | 9 |
| B | 11 | 10 |

| S1 setting | I/O module no. | |
|------------|--------------------|----------|
| | RM-300C RM-400C | RM-1000C |
| C | 12 | 11 |
| D | 13 | 12 |
| E | 14 | 13 |
| F | 15 | 14 |
| | | |

Setting the number of valves (selector switch S2)

| S2 setting | Number of valves |
|------------|------------------|
| 0 | 16 |
| 1 | 1 |
| 2 | 2 |
| 3 | 3 |
| 4 | 4 |
| 5 | 5 |

| S2 setting | Number of valves |
|------------|------------------|
| 6 | 6 |
| 7 | 7 |
| 8 | 8 |
| 9 | 9 |
| A | 10 |
| B | 11 |

| S2 setting | Number of valves |
|------------|------------------|
| C | 12 |
| D | 13 |
| E | 14 |
| F | 15 |
| | |

4 Casing and assembly holders

4.1 Sealed casing

Numerous versions of the standard plastic casing with dimensions 250 mm x 160 mm x 90 mm are available for fitting the *RM-V16* filter control board (see Figure 4).

A distinction is made between casings with integral solenoid valves and those without (see Figure 3). All further information can be found in the separate casing catalogue.

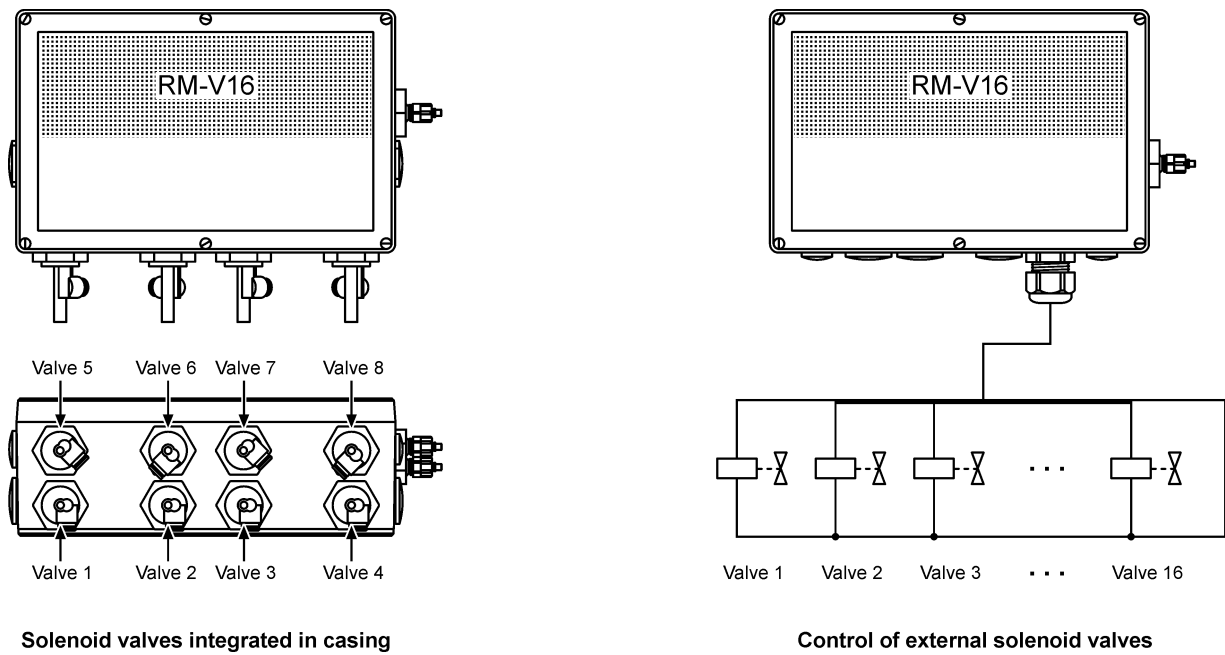

Figure 3: Casing versions for installation of the *RM-V16* board

4.2 Assembly holders

The board of the *RM-V16* can be fixed to a holder to mount carrier rails (see Figure 5).

5 Technical data

| Application | Data | Terminals |
|---|--|--|
| Supply voltage | 24 V DC -0 % / +10 % or 24 V AC -0 % / +10 % | 45, 46 |
| Supply voltage for further modules (output) | Identical to supply voltage (Terminals 45 and 46) | 47, 48 |
| RS-485 bus | <i>R-IMC</i> bus | 49 ... 51 52 ... 54 |
| Outputs for solenoid valves | 16 transistor outputs, 24 V / DC, output power in pulse mode 42 Watt | V1, V2, V3 ... V16 Plus connections on flat pin terminal strip |
| Signal outputs | 2 transistor outputs, 24 V / DC, output power in pulse mode 42 Watt | O1 ¹ , +O ² O2 ¹ , +O ² |
| | 1 analogue outputs 4 ... 20 mA corresponding to 0 ... 5000 Pa if a type SM5000-SP-ST is fitted and selector switch S4 is in 1 position | I1, I+ |
| Signal inputs | 3 digital inputs, 24 V DC, operate ensuring isolation | P1, P+ P2, P+ P3, P+ |
| | 2 analogue inputs, 4 ... 20 mA corresponding to 0 ... 5000 Pa, resistance 500 Ω The 4-20 mA signal must be unearthed! (If a sensor module is fitted, only 1 analogue input is available) | I1, GND I2, GND (4-wire technology) I1, I+ I2, I+ (2-wire technology) |
| Δ <i>p</i> measuring range (only if sensor module is fitted) | 0 ... 5000 Pa | |
| Measurement sensor (only if sensor module is fitted) | piezoresistant excessive pressure-safe up to 120 kPa | |
| Temperature range | - 20°C to + 60°C | |
| Degree of protection when fitted in casing | Casing IP-66, NEMA 4 | |
| Weight | approx. 1,550 g | |
| Installation height | max. 3000 m above M.S.L. | |

¹ +24 V DC

² Minus potential transistor (Open Collector)

6 Scale drawings

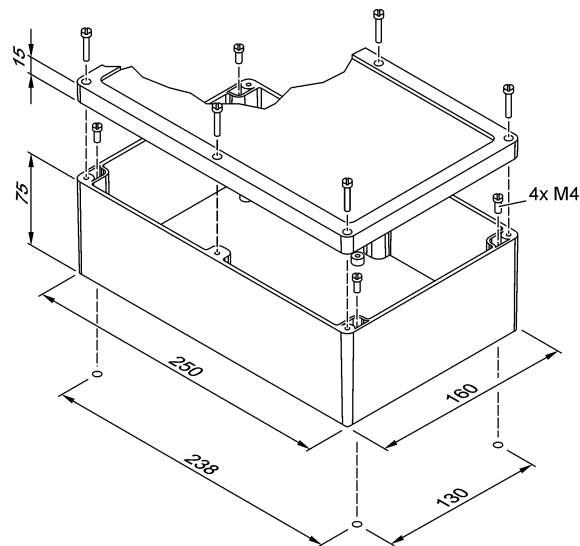

Figure 4: Casing without integral valves

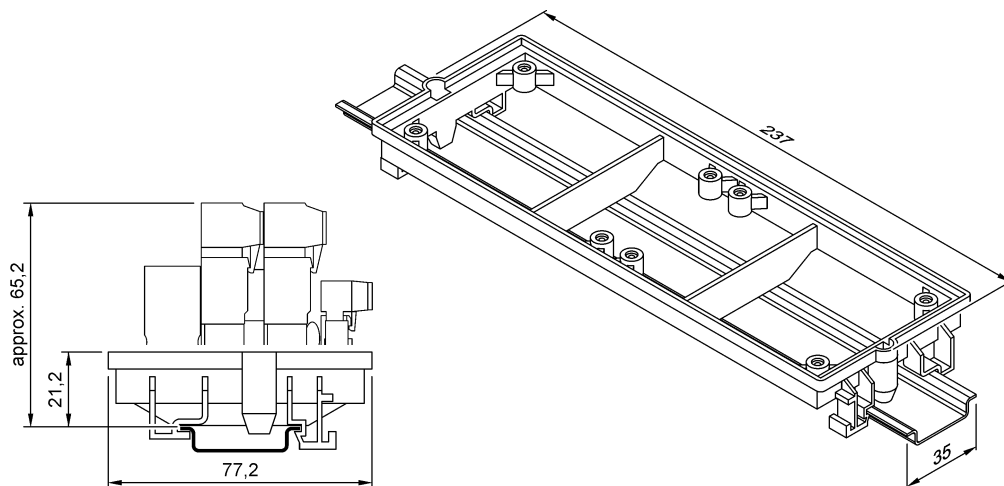

Figure 5: Support bar for carrier rail mounting

Disclaimer

The contents of this documentation has been verified for correctness and completeness. Nevertheless, errors can not be excluded so that we cannot guarantee the correctness of this information. Subject to alterations at any time.