



# Clamping cylinder—MCK Series

## Compendium of MCK Series

### Dustproof and welding slag out design

There is a scraping dust ring in front cover, and it is firm and durable that can avoid dust and splashed welding slag breaking cylinders.

It is more reliable than dust helmet.

Scraping dust ring

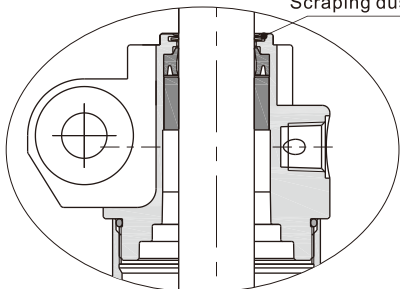

### Two orifice models air available

### Rolling packed structure

Back cover and barrel adopt riveted rolling packed structure to form a reliable connection.

### Y knuckle is available

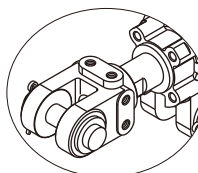

Y : With M6 thread hole

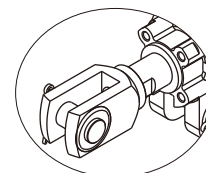

YW : Without M6 thread hole

### Buffer adjustment and speedlimit adjustment are built-in

### Various types of sensor switches are available.

1. The Anti-magnetic sensor should be used with the anti-magnetic bracket. For details, refer to page P334.
2. Common sensors (DMSG/EMSG, CMSG) should be used with the sensor holder (F-MCK40G). Please refer to common sensors for details about DMSG/EMSG and CMSG sensor. The matching sensor holders need to be ordered separately. The ordering method and installation method are as follows:

<b>Sensor holder's ordering code</b>	F-MCK40G(Matching with MCK)
--------------------------------------	-----------------------------

#### Installation steps :

1. The sensor is installed in the G-shaped groove of the sensor fixing base and locked with a slotted screwdriver;
2. The sensor holder is installed on the fixing bar, moves to a proper position and closes to the outer cylinder of the cylinder, and then tightens the hexagonal cap screws with the hexagonal wrench.
3. Avoid mechanical damage during installation;
4. When installing, pay attention to avoid interference with peripheral components

#### Sensor's installation method

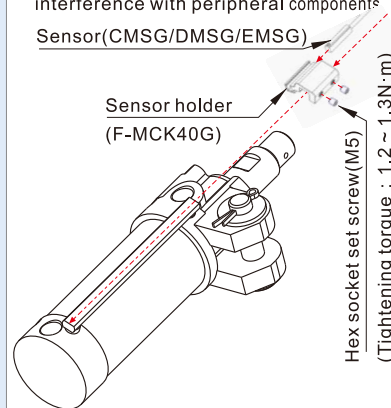

## Theoretical clamping force

Unit : Newton(N)

Bore size	Rod size	Acting type	Operating pressure(MPa)							
			0.1	0.2	0.3	0.4	0.5	0.6	0.7	0.8
40	20	Double acting Push side	125.6	251.2	376.8	502.4	628.0	753.6	879.2	1004.8
		Pull side	94.2	188.4	282.6	376.8	471.0	565.2	659.4	753.6
50	20	Double acting Push side	196.3	392.6	588.9	785.2	981.5	1177.8	1374.1	1570.4
		Pull side	164.9	329.8	494.7	659.6	824.5	989.4	1154.3	1319.2
63	20	Double acting Push side	311.7	623.4	935.1	1246.8	1558.5	1870.2	2181.9	2493.6
		Pull side	280.3	560.6	840.9	1121.2	1401.5	1681.8	1962.1	2242.4
80	25	Double acting Push side	502.6	1005.2	1507.8	2010.4	2513.0	3015.6	3518.2	4020.8
		Pull side	453.6	907.2	1360.8	1814.4	2268.0	2721.6	3175.2	3628.8

## Installation and application



1. In normal situation such as: edge packing, installation, jig test...and so on. Standard cylinder is suggested.
2. In case of high-magnetic field generated by welding in the vicinity, anti-magnetic welding clamp cylinder shall be used and corresponding anti-magnetic sensor switch shall be matched.
3. Before cylinder connecting, the dust must be eliminated to avoid it entering in the cylinder.
4. The medium used by cylinder shall be filtered to 40μm or below.
5. Under high temperature environment, the cylinder of high-temperature resistance shall be selected. Anti-freezing measure shall be adopted under low temperature environment to prevent the water freezing in cylinder.
6. If cylinder is not used for a long time, please advert the surface to get rusty. Inlet and outlet ports should have anti-dust caps and also spread the oil to avoid getting rusty on piston rod.

## Application examples

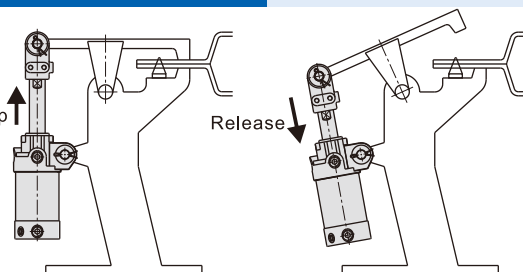

# Clamping cylinder

## MCK Series



### Specification

Bore size(mm)	40	50	63	80
Acting type	Double acting			
Fluid	Air(to be filtered by 40μm filter element)			
Operating pressure	0.15~1.0MPa(22~145psi)			
Proof pressure	1.5MPa(215psi)			
Temperature	-20~70 °C			
Speed range	50~500mm/s			
Cushion type	Variable cushion for back cover or front cover(optional)			
Speed controlled valve	Standard setting for covers			
Lubrication	Not required			
Installation type	Double hinged-supports			
Port size [Note1]	1/4"		3/8"	

[Note1]PT thread, G thread are available.

### Product feature

1. It suits for workshops that make automation welding.
2. There is a scraping dust ring in front cover, and it is firm and durable that can avoid dust and splashed welding slag breaking cylinders. It is more reliable than dust helmet.
3. It fits the working environment where has strong magnetic field, if it uses the sensor switch which is with strong magnet and anti-strong magnetic field.
4. Inlet interface are optional on three sides; buffer adjustment and speed limit adjustment are built-in.
5. Various types of sensor switches are available.

### Symbol

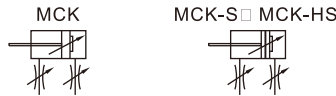

### Stroke

Bore size(mm)	Standard stroke(mm)	Available stroke
50 75 100 125 150	150	150

Remark) Consult us for non-standard stroke.

### Ordering code

MCK A 50×75 S □ Y □  
 ① ② ③ ④ ⑤ ⑥ ⑦ ⑧

① Model	② Orifice model	③ Bore size	④ Stroke	⑤ Magnet	⑥ Mounting type	⑦ Mounting type	⑧ Thread type
MCK: Clamping cylinder (Double acting)	A: Orifice model A	40	Refer to Stroke table for detail	Blank: Without magnet S: With normal magnet[Note1]	Blank: Three groups air port in the front and back cover (Variable cushion for back and front cover)  Variable cushion for back cover and front cover	Blank: Without Y knuckle  Y : With Y knuckle (With M6 thread hole) YW : With Y knuckle (No M6 thread hole)  	Blank: PT G: G
	B: Orifice model B	50					
		63					
	No this code	80					

[Note1] In powerful magnetic field, sensor switch for high-magnet shall be matched. Please refer to Page 343 for option.

### Inner structure and material of major parts

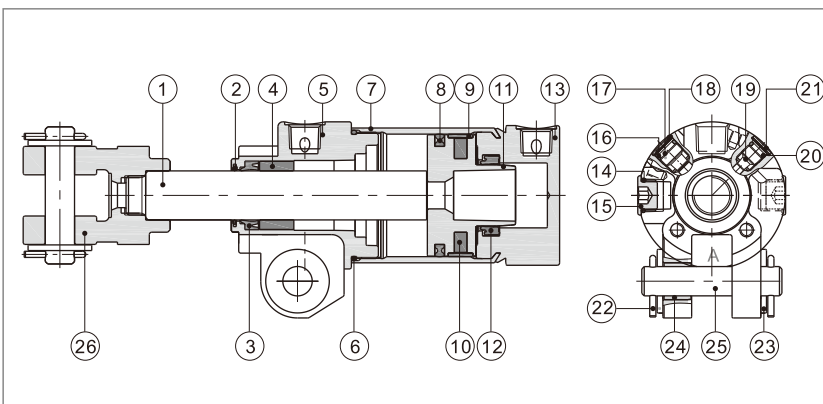

No.	Item	Material	No.	Item	Material
1	Piston rod	Carbon steel	15	Stop screw	S35C
2	Scraping dust ring	Stainless steel	16	O-ring	NBR
3	Spool packing	NBR	17	Cush controlled screw	Aluminum alloy
4	Sliding bushing	Aluminum alloy	18	Bead flange	Spring steel
5	Front cover	Aluminum alloy	19	Speed controlled screw	Aluminum alloy
6	O-ring	NBR	20	O-ring	NBR
7	Barrel	Aluminum alloy	21	Bead flange	Spring steel
8	Piston O-ring	NBR	22	Orifice Pin	Midl steel
9	Wear ring	Wear resistant material	23	Cover blake	SPCC
10	Magnet	Magnetism material	24	Sliding bushing	Wear resistant material
11	Piston	Aluminum alloy	25	Pin	S45C
12	Cushion O-ring	TPU	26	Y knuckle	Nodular cast iron
13	Back cover	Aluminum alloy			
14	O-ring	NBR			



# Clamping cylinder

## MCK Series

### Dimensions

#### Φ40/50/63(Without magnet)

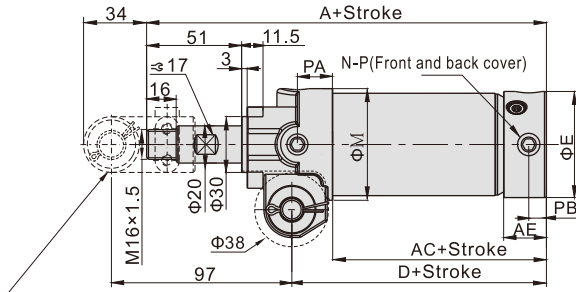

If it goes with hinged-support, the width would be the same with front cover of cylinder.

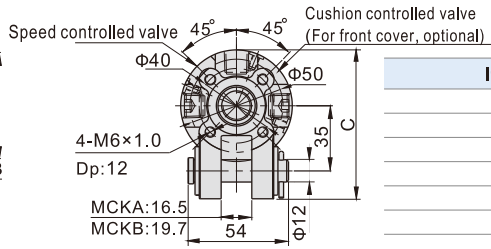

Item\Bore size		40	50	63
A		162	165	167
AC		59	65	67
AE		20	22	23
C		76	80	87
D		84	87	89
E		47	57	70
M		52	60	74
N (Number of hole)	Variable cushion for back and front cover	6	6	6
	Variable cushion for back cover	2	2	2
P(Inlet and out let port)		1/4"		
	PA	20	19	19
	PB	9	9.5	9.5

#### Φ40/50/63(With magnet)

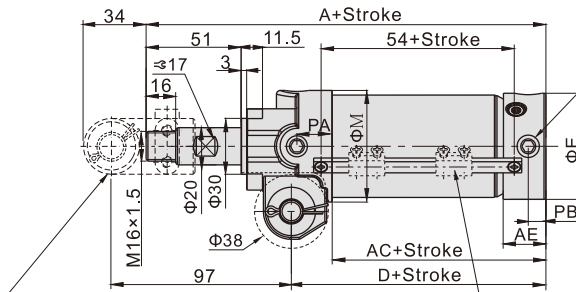

If it goes with hinged-support, the width would be the same with front cover of cylinder.

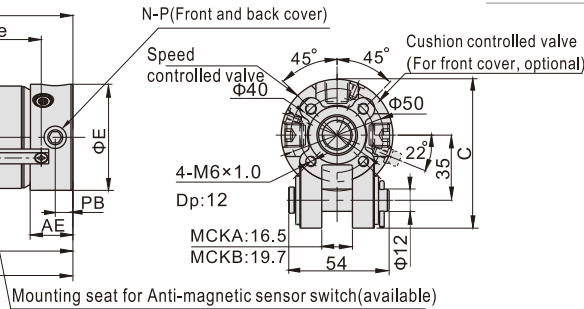

#### Φ80(Without magnet)

If it goes with hinged-support, the width would be the same with front cover of cylinder.

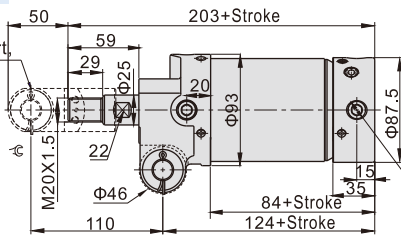

Variable cushion for back and front cover type : 6-3/8"  
Variable cushion for back cover type : 2-3/8"

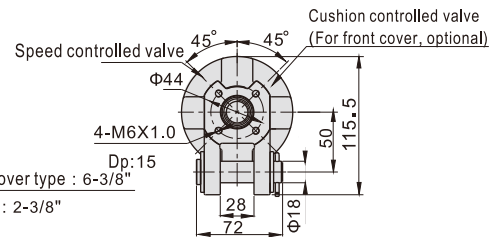

#### Φ80(With magnet)

If it goes with hinged-support, the width would be the same with front cover of cylinder.

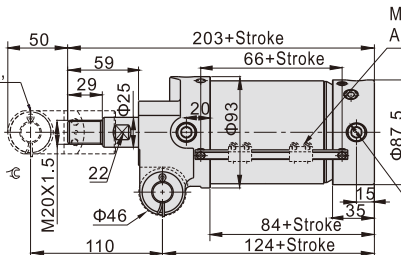

Variable cushion for back and front cover type : 6-3/8"  
Variable cushion for back cover type : 2-3/8"

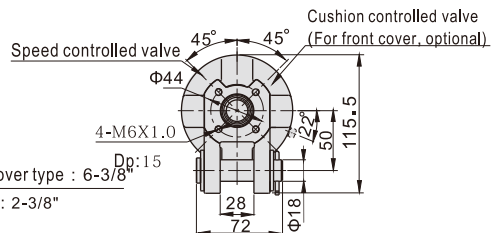

## MCK Series

### Specifications and ordering codes of Y knuckle

#### Φ40/50/63

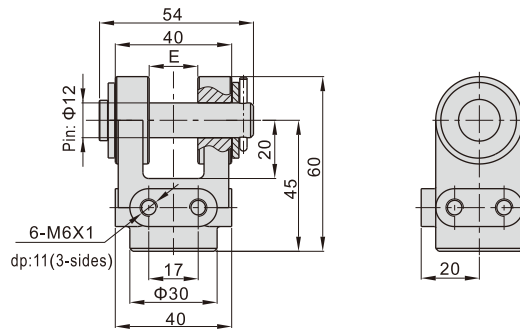

Model	Ordering code	Applicable bore size	E
MCKA	MCKA50-Y	40\50\63	16.5
MCKB	MCKB50-Y	40\50\63	19.5

#### Φ80

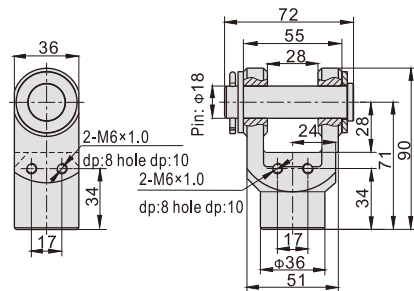

Model	Ordering code	Applicable bore size
MCK	MCK80-Y	80

# Clamping cylinder

## Sensor switch—DS1-69AM Series



### Feature

DS1-69AM series are anti-magnetic sensor switch, which are for AC magnetic environment.

### Ordering code

DS1-69AM	
①	②
① Number of sensor switch	② Code
	69AM: Anti-magnetic sensor switch (AC resistant welder)

### Specification

Item\Type	DS1-69AM
Switch logic	Transistor without contact, normally opened type
Sensor type	Transistor, two-line, nonpolarity
Operating voltage (V)	10~30V/DC
Max. Switching current	100mA Max.
Switching Rating (W)	3W Max.
Anti-magnetic current	AC 17000A
Voltage drop	4.8V Max. @100mA DC
Leakage current	0.6mA Max. @30V DC
Min. working current	3mA Min.
Indicator	Stable range:Green LED ; Non-table range:Red LED
Cable	Φ5.3/0.5SQ×2C×3m/oil resistant, Flame retarded, flection/gravy PVC
Sensitivity	30~40 Gauss
Max. Frequency	8Hz
Temperature range	-10~70°C
Shock	50m/s <sup>2</sup>
Vibration	9m/s <sup>2</sup>
Protection	IP 67(EN60529)
Protection circuit	Transistor without contact, surge suppression
Fire retardant grade	UL94-V0

### Dimensions

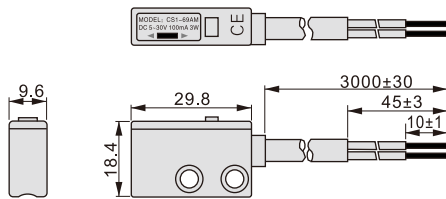

### Wiring diagram

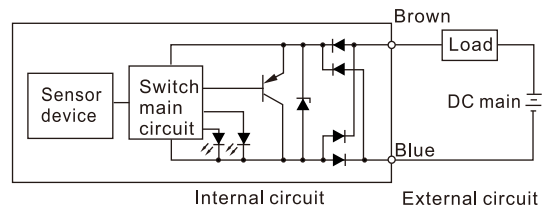

### Mounting

In powerful magnetic field, sensor switch for high-magnet shall be matched, and the anti-magnetic bracket (F-MCK40H for MCK series or F-AQK50H for AQK50 Series) must be ordered separately, the ordering code, dimensions and the mounting method are below:

Ordering code	Dimensions	Mounting
F-MCK40H (For MCK Series)		
F-AQK50H (For AQK50 Series)		

### Indicator action illustration

