

SINEAX F535

Transducer for measuring frequency difference

Carrying rail housing P13/70

Application

The transducer **SINEAX F535** (Fig. 1) converts the frequency difference of two synchronised supplies into a **load independent** DC current or a **load independent** DC voltage proportional to the measured value.

The transducer fulfils all the important requirements and regulations concerning electromagnetic compatibility **EMC** and **Safety** (IEC 1010 resp. EN 61 010). It was developed and is manufactured and tested in strict accordance with the **quality assurance standard** ISO 9001.

Features / Benefits

- **Measuring inputs: Sine, rectangular, or distorted wave forms of nominal input voltages with dominant fundamental waves**

Measured variables	Nominal input voltages	Measuring range limits
Frequency difference	10 to 690 V	$\Delta = \pm 1\% f_s$ to $\pm 80\% f_s$ $10 \text{ Hz} \leq f_G \leq 1000 \text{ Hz}$, $16 \text{ Hz} \leq f_s \leq 800 \text{ Hz}$

- **Measuring output: Unipolar, bipolar or live zero output variables**
- **Measuring principle: Digital period measurement**
- **AC/DC power supply / Universal**
- **Standard as with maritime execution (formerly GL, Germanischer Lloyd)**

Technical data

General

Measured quantity: Frequency difference Δf
 Measuring principle: Digital period measurement

Measuring inputs

Measuring range (f_s = bus bar, f_G = generator): See Section "Specification and ordering information"

Nominal input voltages U_N : Generator and bus bar
 CE: 10 ... 230 V or > 230 ... 690 V
 CSA: 10 ... 230 V or > 230 ... 600 V (max. 230 V with power supply from voltage measuring input)

Own consumption: $< U_N \cdot 1.5 \text{ mA}$ per measuring input



Fig. 1. Transducer SINEAX F535 in housing P13/70 clipped onto a top-hat rail.

Overload capacity:

Measured quantities U_N	Number of applications	Duration of one application	Interval between two successive applications
$1.2 \times U_N^1$	—	continuously	—
$2 \times U_N^1$	10	1 s	10 s

¹ But max. 264 V with power supply from voltage measuring input

Wave form: Any; fundamental wave only taken into account

Measuring output

Load independent DC current: 0 ... 1 to 0 ... 20 mA resp. live-zero
 1 ... 5 to 4 ... 20 mA
 ± 1 to $\pm 20 \text{ mA}$

Burden voltage: + 15 V, resp. - 12 V

Load independent DC voltage: 0 ... 1 to 0 ... 10 V resp. live-zero
 0.2 ... 1 to 2 ... 10 V
 ± 1 to $\pm 10 \text{ V}$

Load capacity: Max. 4 mA

Voltage limit under $R_{ext} = \infty$: $\leq 25 \text{ V}$

SINEAX F535

Transducer for measuring frequency difference

Current limit under overload:

Approx. $1.3 \times I_{AN}$ at current output
Approx. 30 mA at voltage output

Residual ripple in output current:

< 0.5% p.p.

Nominal value of response time:

4 periods of the measuring frequency

Other ranges:

2, 8 or 16 periods of the measuring frequency

Behaviour of output current in different operating states:

Operating state ¹		Output	Display
Generator frequency	Bus frequency		
$f_G > f_S$		unipolar	$> I_{AN} / 2$
		bipolar	positive
missing ²	nominal value	unipolar	approx. 0
		bipolar	approx. $-110\% I_{AN}$
nominal value	missing ²	unipolar	approx. $+110\% I_{AN}$
		bipolar	
missing ²	missing ²	unipolar	approx. $I_{AN} / 2$
		bipolar	approx. 0

¹ With power supply switched on

² E.g. switched off or fault condition

Accuracy (acc. to EN 60 688)

Reference value: Output span

Basic accuracy: Class 0.2

Reference conditions

Ambient temperature: 15 ... 30 °C

Input voltage: U_{min} to U_{max}

Distortion factor: No influence

Power supply: At nominal range

Output burden: ΔR_{ext} max.

Safety

Protection class: II (protection isolated, EN 61 010)

Housing protection: IP 40, housing (test wire, EN 60 529)
IP 20, terminals (test finger, EN 60 529)

Contamination level: 2

Overvoltage category: III

Rated insulation voltage (against earth): 230 resp. 400 V, input
230 V, power supply
40 V, output

Test voltage: 50 Hz, 1 min. acc. to EN 61 010-1
3250 V, input U_G versus input U_S
3700 resp. 5550 V, inputs versus all other circuits as well as outer surface
3700 V, power supply versus output as well as outer surface
490 V, output versus outer surface

Power supply →○

AC/DC power pack (DC or 50/60 Hz)

Table 1: Rated voltages and permissible variations

Rated voltage	Tolerance
85 ... 230 V DC, AC	DC $-15 \dots +33\%$
24 ... 60 V DC, AC	AC $\pm 15\%$

or power supply from voltage measuring input:

24 ... 60 V AC or 85 ... 230 V AC,
Note: $40 \text{ Hz} \leq f \leq 400 \text{ Hz}$

Option:

Connect to the low tension to terminals 12 and 13
24 V AC or 24 ... 60 V DC

Power consumption:

3 VA

Installation data

Mechanical design:

Housing **P13/70**

Material of housing:

Lexan 940 (polycarbonate)
flammability Class V-0 acc. to UL 94, self-extinguishing, non-dripping, free of halogen

Mounting:

For rail mounting

Mounting position:

Any

Weight:

Approx. 0.27 kg

Connecting terminals

Connection element:

Screw-type terminals with indirect wire pressure

Permissible cross section of the connection leads:

$\leq 4.0 \text{ mm}^2$ single wire or
 $2 \times 2.5 \text{ mm}^2$ fine wire

Environmental conditions

Operating temperature: -10 to $+55 \text{ °C}$

Storage temperature: -40 to $+70 \text{ °C}$

Relative humidity: $\leq 75\%$, no dew

Altitude: 2000 m max.

Indoor use statement!

Ambient tests

EN 60 068-2-6: Vibration

Acceleration: $\pm 2 \text{ g}$

Frequency range: 10 ... 150 ... 10 Hz, rate of frequency sweep: 1 octave/minute

Number of cycles: 10, in each of the three axes

EN 60 068-2-27: Shock

Acceleration: $3 \times 50 \text{ g}$

3 shocks each in 6 directions

EN 60 068-2-1/-2/-3: Cold, dry heat, damp heat

IEC 1000-4-2/-3/-4/-5/-6

EN 55 011: Electromagnetic compatibility

Maritime product features (formerly GL, Germanischer Lloyd)

Type approval certificate: No. 12 261-98 HH

Ambient category: C

Vibration: 0.7 g

SINEAX F535

Transducer for measuring frequency difference

Output characteristic

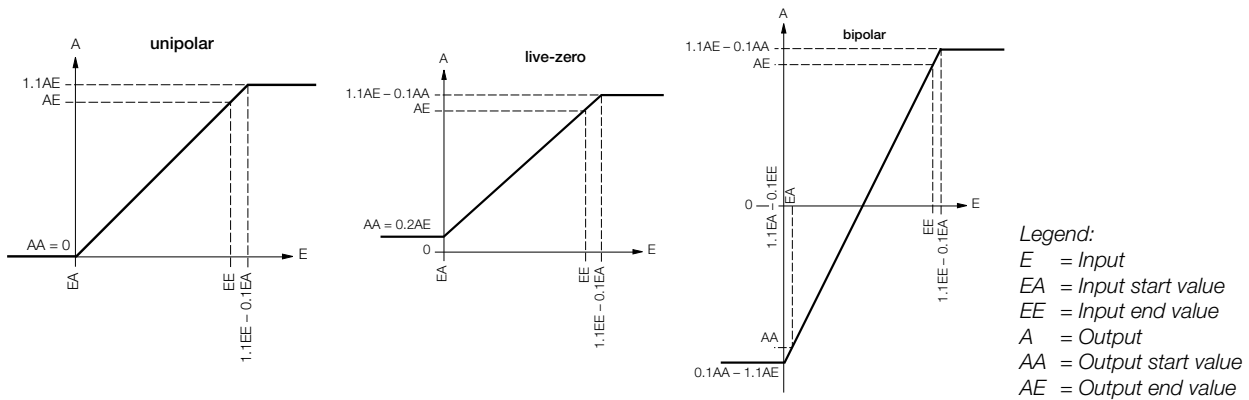

Table 2: Specification and ordering information

Description	*Blocking code	no-go with blocking code	Article No./ Feature
SINEAX F535			535 –
Order code 535 - xxxx xx			
Features, Selection			
1. Mechanical design Housing P13/70 for rail mounting			4
2. Nominal input voltage Generator and bus bar: U_N : 10 ... 230 V U_N : > 230 ... 690 V Not possible with power supply from measuring input 3 phase system: Input voltage = phase to phase voltage	A		1 2
3. Measuring range Frequency: Bus bar = f_s / Generator = f_G $f_s = 50$ Hz / $f_G = 49.5 \dots 50 \dots 50.5$ Hz $f_s = 50$ Hz / $f_G = 47.5 \dots 50 \dots 52.5$ Hz $f_s = 50$ Hz / $f_G = 45 \dots 50 \dots 55$ Hz $f_s = 50$ Hz / $f_G = 40 \dots 50 \dots 60$ Hz $f_s = 60$ Hz / $f_G = 57.5 \dots 60 \dots 62.5$ Hz Non-standard limit values [Hz] $\Delta f \pm 1\% f_s$ to $\pm 80\% f_s$ $10 \text{ Hz} \leq f_G \leq 1000 \text{ Hz}$, $16 \text{ Hz} \leq f_s \leq 800 \text{ Hz}$ With power supply from measuring input: $40 \text{ Hz} \leq f_s \leq 400 \text{ Hz}$, see feature 5, lines 3 and 4			1 2 3 4 5 9
4. Output signal 0 ... 20 mA 4 ... 20 mA Non-standard 0 ... 1.00 to 0 ... < 20, [mA] - 1.00 ... 0 ... 1.00 to - 20 ... 0 ... 20 (symmetrical) 1 ... 5 to < (4 ... 20) (AA/AE = 1/5) 0 ... 10 V Non-standard 0 ... 1.00 to 0 ... < 10, [V] - 1.00 ... 0 ... 1.00 to - 10 ... 0 ... 10 (symmetrical) 0.2 ... 1 to 2 ... 10 (AA/AE = 1/5) AA = Output start value, AE = Output end value			1 2 9 A Z

SINEAX F535

Transducer for measuring frequency difference

Description	*Blocking code	no-go with blocking code	Article No./ Feature
SINEAX F535	Order code 535 - xxxx xx		535 -
Features, Selection			
5. Power supply			
85 ... 230 V DC, AC			1
24 ... 60 V DC, AC			2
Internal from measuring input (85 ... 230 V AC)		A	4
Connect to the low tension 24 V AC / 24 ... 60 V DC			5
6. Response time			
4 periods of the input frequency (standard)			1
2 periods of the input frequency			2
8 periods of the input frequency			3
16 periods of the input frequency			4

* Lines with letter(s) under "no-go" cannot be combined with preceding lines having the same letter under "Blocking code".

Electrical connections

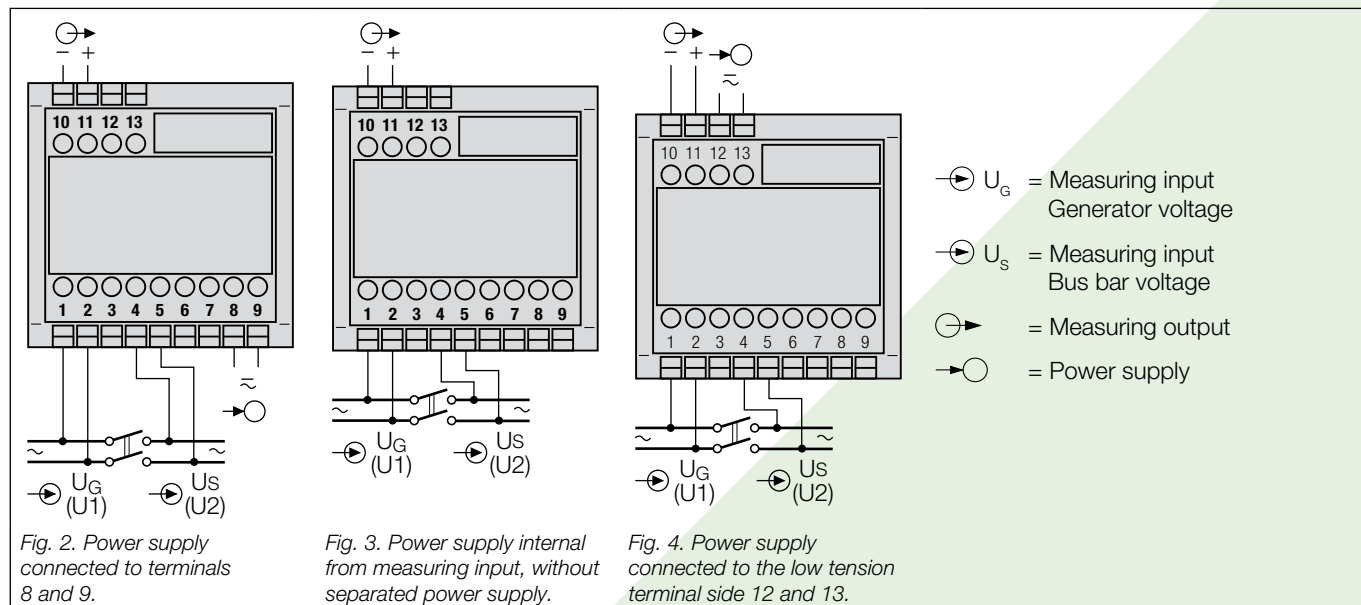

Dimensional drawing

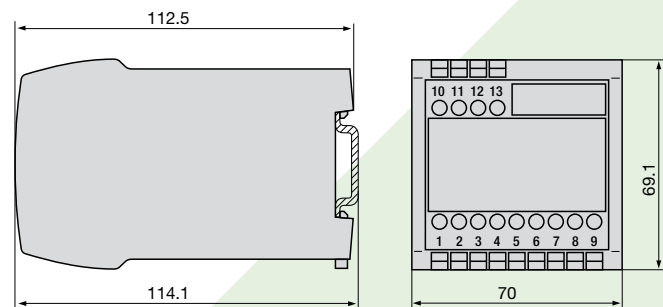

Fig. 5. Housing P13/70 clipped onto a top-hat rail (35 x 15 mm or 35 x 7.5 mm, acc. to EN 50 022).

Standard accessories

1 Operating instructions in three languages: German, French, English



CAMILLE BAUER

Camille Bauer Metrawatt Ltd
 Aargauerstrasse 7
 CH-5610 Wohlen / Switzerland
 Telephone: +41 56 618 21 11
 Telefax: +41 56 618 21 21
 info@cbmag.com
 www.camillebauer.com