

Actuator Unit – Rotary Cylinder

RTM, RMF, RTB, RTBM, RTZB, RTP, RTH, RTU series

CHELIC



RTM, RTB, RTBM, RTZB
RTP, RTH, RTU series
Provide CAD external dimension.

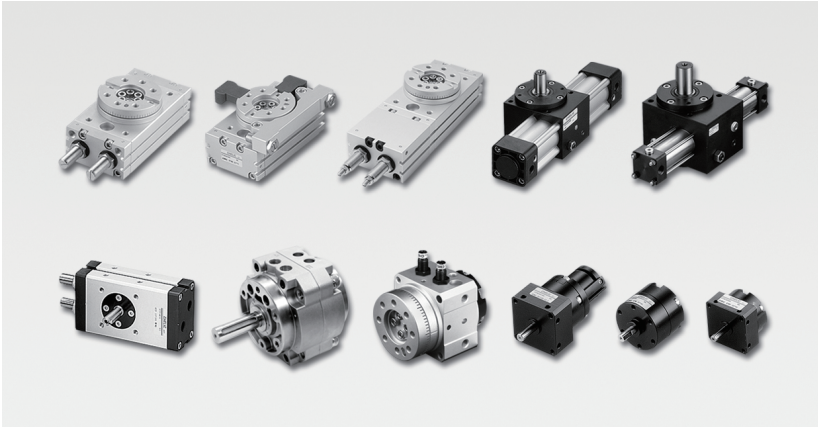

RTM series --- Rotary actuators ----- 10, 15, 20, 30, 40 ----- P.6-12.11
(Vane type)



RTM series --- Rotary actuators ----- 50, 63, 80, 100 ----- P.6-12.20
(Vane type)



RMF series --- Rotary table ----- 10, 15, 20, 30, 40, 50 ----- P.6-12.26

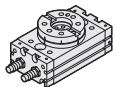

RTB series --- Rotary table ----- 3, 7, 10, 20, 30, 50 ----- P.6-12.35
70, 100, 200, 300, 500

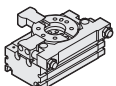

RTBM series --- Rotary table ----- 10, 20, 30, 50, 70, 100 ----- P.6-12.50

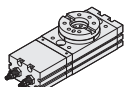

RTZB series --- 3-Position rotary table ----- 10, 20, 30, 50 ----- P.6-12.55

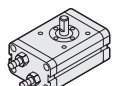

RTP series --- Rotary actuator ----- 5, 10, 20, 30 ----- P.6-12.62

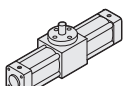

RTH series --- Rotary cylinder ----- 40, 63, 80 ----- P.6-12.66

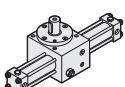

RTU series --- Hydraulic cylinder ----- 32, 40 ----- P.6-12.67



Safety Notice/ Common Caution ①

CHELIC



Please read this safety notice carefully, pay attention to safety item while using this product, in order to prevent injury to human body and damage of property; thus, there are divided into three classes of "Danger", "Warning", and "Caution" according to the extend of prevention.



DANGER

Obviously situated at "DANGER" state, may cause casualty if not avoided; take special safety protection and management to prevent the occurrence of "DANGER"



WARNING

Condition of operation is situated at "DANGER" state, may cause casualty if not avoided; take special safety protection and management to prevent the occurrence of "DANGER"



CAUTION

Condition of operation is situated at "DANGER" state, may cause minor or moderate injury and damage of property if not avoided; take safety protection and management

- For safety protection and prevention of accident, please understand the condition of application and know the design, installation, procedure of usage and essential safety condition before using this product.
- Please use within the specification and requirement of this product; application beyond the specification may cause hazard. In case of special condition of application, take the confirmation of safety into account and then use it; in case of doubt in reading this information and related data, contact us before using.
- It is hazardous in error assemble and operation of compressed air and its accessories; so, while selecting the product, the related personnel of design, assemble, operating and service should possess sufficient knowledge and experience, and follow normal operating procedure, in order to maintain safe operation and good effect.
- The safety notice is made according to ISO 4414; pneumatic fluid power and JSI B 8370 general requirement of air system.

※ The safety notice, if change anything, excuse we don't notify.



Safety Notice/ Common Caution ②

CHELIC



This product suitable for application in general industrial equipment; adhere to the following caution while designing, assembling, using and maintenance.

DANGER

1 . Please never use in following application

- Use in operation, delivering and management of the appliance for the purpose of human life and body.
- Use in operation which rise obvious “Danger” and safety concern to human life and body.
- Special for safety purpose, situation with impact of safety to human life and body.

2 . Confirmation of safety shall avoid the following conditions which cause safety impact to human and damage of equipment.

- Operation of machine, device should note to the drop of driven object or race at the rotation radius and operation range cause injury of human and damage of equipment.
- Operation of machine, device should note the air supply source and poor power supply and interruption and cause injury of human and damage of equipment.
- When restarting the machine, device may cause object flying out and cause injury of human and damage of equipment.

WARNING

1 . Please never use in following situation

- In outdoor dusty condition.
- Avoid chemical, corrosive and inflammable gas; avoid sea water, high temperature place in surrounding.
- Exceed the condition in the specification of the product.
- In the place tend to receive rigorous shock impact, which affect the quality and stability of the product.

2. Please don't make any modification or disassemble to the structure, function of the product.

3. Shut off the power switch and air source properly before service and maintenance, avoid consequent hazard and damage of product.

4. Avoid consequent hazard and damage of product while assembling and operation.

CAUTION

1. Pay attention to the cleanliness of the pipeline while laying the pipe, avoid dust, dirt and leak proof tape been sucked into the pipeline, affect the operation performance of the product.

2. There are itemized cautions for various product, please contact our sale personnel if any doubt arouse.



Safety Notice/ Rotary Cylinder/ Caution For Application

CHELIC



Please read this safety notice carefully, pay attention to safety item while using this product, in order to prevent injury to human body and damage of property.

Caution for service and Selection



WARNING

- Make thorough understanding to the characteristic of the compressed air and the application of this product while designing circuit.
- Please use only the fluid stated on the catalog, don't use the fluid other than limited, in order to prevent damage of product and affect the operation safety.
- The air used is compressed air, please note that expandable and unstable pressure will fly out, burst out, or leak.
- Please used as per specification and within the specified condition; use exceed the specification may cause hazard.
- Please used as per the specification stated on the catalog, exceeding the pressure beyond the specification, temperature and condition will cause poor action and affect the operation safety.
- Due to the mechanical design of the revolving cylinder with variation of wobbling movement, please pay attention to flying objects and possible crash hazard of your limbs, which may result in body injury and mechanical damage and so on; please take precaution upon designing.
- The movable range of revolving cylinder may contact our body and cause injury, should be protected by safety guard to prevent direct contact of body hazard.
- For larger mechanism or long stroke object, the revolving cylinder must equip with buffer device and provide with deceleration circuit to reduce and sooth the rigid impact of the mechanism device.
- Take the emergency or transient cut off power source, or power failure, air source circuit pressure drop causing holding force drop, vertical movement slip and resulting in damage of mechanical device, and human safety into account upon designing, so, safety countermeasure should be take in design.
- Take the driving mechanism and circuit control system combination into account upon design, avoid residue pressure in circuit, fail to completely positioning and lateral pressurized and other actor, causing high speed fly out of the object. These situations are very possible to cause body injury and limbs crashed, and damage of mechanism. Countermeasure of protective circuit is necessary.
- Emergency stop device for mechanism is essential. In case of malfunction, in addition to protective device, emergency stop device should be provided in order to prevent body injury and damage of equipment.
- Re-start after emergency stop should confirm safety position of all mechanism, avoid interference and impact due to error position, affect human body and damage the equipment; there should have safety precaution countermeasure for restarting after emergency stop upon design.



Safety Notice/ Rotary Cylinder/ Caution For Application

CHELIC



CAUTION

- Adjusting slightly for the angle of rotary cylinder will make the angle to change.
- The magnetic on the cylinder slide base should keep distance from iron plate and magnetic object to prevent the cause of error induction, and should avoid too close to other magnetic related sensor and the range of slide base stroke and induce error induction.
- Please don't apply external process to revolving cylinder to change the profile and structure, causing insufficient strength and structure damage, part damage.
- Please don't enlarge the vent hole of inlet, enlarged bore increase rocking speed and inert torque instant impact, lead to structure damage of product and human injury.
- Fixation of the rotation shaft and object should avoid the phenomena of eccentric and interference, the best method is adopting floating or axial coupling with freeness.

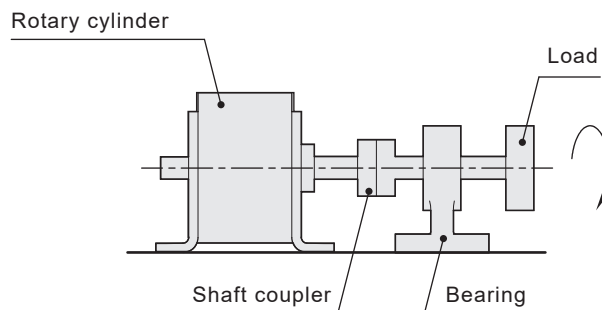

- If the revolving cylinder receives axial load, avoid direct load on shaft, this will tend to damage of internal structure of the revolving cylinder, the best mean is to add the load by using fixture to the shaft, the shaft, the revolving cylinder serve only revolving movement.

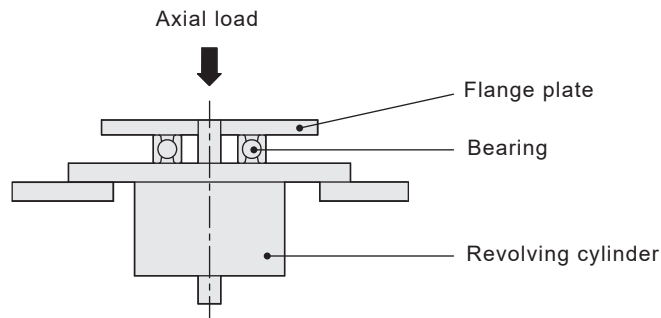

- Please don't hammer the revolving shaft and body while revolving shaft is fixing, to avoid bend deformation of revolving shaft and damage deformation of the body.
- The best controlling method of angular positioning of the revolving cylinder is adopting external positioning method, match with positioning screw or hydraulic buffer to control direct stop.



Safety Notice/ Rotary Cylinder/ Caution For Application

CHELIC



Please read this safety notice carefully, pay attention to safety item while using this product, in order to prevent injury to human body and damage of property.

Safety notice

Caution for service and maintenance

WARNING

- Shut off the power switch and air source properly before service and maintenance, confirm that there is no residue pressure in the pipeline and start work after confirming the status is safe.
- Please don't disassemble the revolving cylinder in discretion, disassemble the revolving cylinder in discretion will lead to displacement of the original calibration accuracy; error disassembling will lead to hazard and cause problem on operation of the product.

CAUTION

- The cylinder is coated with small amount of oil at initial using state, it will decrease after a period of usage, and should be added up with appropriate amount of oil according to actual application condition, lubricant is essential in high speed moving, limit to use ISO-VG32 lubricant, feed by oil applicator, may cause poor action if stop oiled when it is required.
- **Service and maintenance should be perform regularly as schedule, and confirm the normal operation of following:**
 - (1) Is the compressed air supplied stably?
 - (2) Is the front filter and strainer normally?
 - (3) Is the connection portion or piping loosen accompany moving of object? Is the pipe connection portion normal? Any strange noise?
 - (4) Is the action condition of the cylinder normally? Is there any delay phenomena and exhaust normally? Any strange noise?
 - (5) Whether the piping system connected to solenoid valve (governor) normally? Do the start of terminal and the action of stop move normally? Is the load system normally?
 - (6) Is the lubricant feeding system normally? Is the volume of oil adjusted properly?



Safety Notice/ Rotary Cylinder/ Caution For Application

CHELIC

Model selection

● Please follow the steps as following to select machine type

1. Operating condition
2. Require torque
3. Calculation of inertial
4. Confirmation of rotation time
5. Calculation of kinetic Energy

● 1. Operating conditions are as follows

Please list operating conditions or ask sales representatives before selecting rotary cylinder. It will make more convenient for the data calculated in the future.

- Operating pressure
- Installing type
- Load type
 - Static load: T_s (N·m)
 - Resistance load: T_f (N·m)
 - Inertial load: T_a (N·m)
- Load dimensions
- Rotation time
- Rotation angle
- Load mass

● 2. Calculation of Required Torque

There are three types will be considered on the load type in the rotary cylinder

Static load	Resistance load	Inertial load
When the pressing force is necessary $T_s = F \cdot L$ F : Clamp force L : Distance from the center of rotation to clamp(m)	When friction force or gravity is applied to the rotation direction $T_f = \mu \cdot m \cdot g \cdot L$ m : Mass of load g : 9.8 m/s ² L : Distance from the center of rotation to the gravity μ : Coefficient of friction	When the load with inertia is rotated $T_a = I \cdot \omega = I \cdot \frac{2\theta}{t^2}$ I : Moment of inertia ω : Angular acceleration θ : Rotation angle t : Rotation time
Rotary torque $\geq T_s$	Rotary torque $\geq (3\sim 5) \times T_f$	Rotary torque $\geq 10 \times T_a$



Safety Notice/ Rotary Cylinder/ Caution For Application

CHELIC

Model selection

3. Calculation of inertial

It is necessary to know the moment of inertia of the load in order to determine the value of necessary torque or kinetic energy when selecting a rotary actuator. Please consider the inertial, rotation time... etc of load when selecting machine.

■ Please check calculation of inertial as following

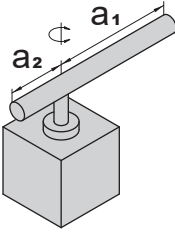
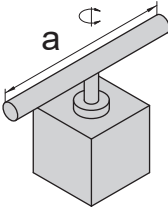
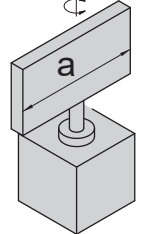
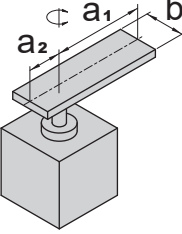
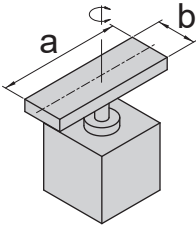
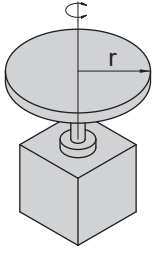
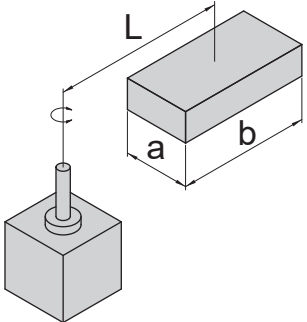
Thin movement	Thin shaft	Thin rectangular plate
<p>1</p>  $I = m_1 \cdot \frac{a_1^2}{3} + m_2 \cdot \frac{a_2^2}{3}$	<p>2</p>  $I = m \cdot \frac{a^2}{12}$	<p>3</p>  $I = m \cdot \frac{a^2}{12}$
Thin movement including rectangular parallelepiped	Thin rectangular plate including rectangular parallelepiped	Round plate including rectangular parallelepiped
<p>4</p>  $I = m_1 \cdot \frac{4a_1^2 + b^2}{12} + m_2 \cdot \frac{4a_2^2 + b^2}{12}$	<p>5</p>  $I = m \cdot \frac{a^2 + b^2}{12}$	<p>6</p>  $I = m \cdot \frac{r^2}{12}$
<p>If load is not in the center of rotation move a distance. If the center of rotation and load is connected by jig, it should calculate inertial of jig and plus load.</p>		
<p>7</p>  $I = m \cdot \frac{a^2 + b^2}{12} + m \cdot L^2$ <p>a, b : The length and wide of load L : Distance from center of rotation to thin m : Load mass</p>		



Safety Notice/ Rotary Cylinder/ Caution For Application

CHELIC

Model selection

4. Confirmation of Rotation Time

Rotation time adjustment range is specified for each product for stable operation. Set the rotation time

■ specified below

Model	Specification	Rotation time adjustment range sec / 90°
RTM RTMF	10, 15, 20	0.03~0.3
	30	0.04~0.3
	40	0.07~0.5
	50, 63, 80, 100	0.1~1
RTP	5, 10	0.2~0.7
	20, 30	0.2~1
RTB RTBM	3	0.2~0.7
	7, 10, 20, 30, 50	0.2~1
	70, 100, 200	0.5~2
	300, 500	1~3
RTH	40, 63, 80	0.8~3

5. Calculation of Kinetic Energy

Kinetic energy is generated when the load rotates. Kinetic energy applies on the product at the operating end as inertial force, and may cause the product to damage. In order to avoid this, the value of allowable kinetic energy is determined for each product.

■ Use the following formula to calculate the kinetic energy of the load

$$E = \frac{1}{2} \cdot I \cdot \omega^2 \qquad \omega = \frac{2\theta}{t}$$

E : Kinetic energy (J)

I : Moment of inertia (kg · m²)

ω : Angle speed (rad / s)

θ : Rotation angle (rad)

Rotation angle 180° =3.14 rad , 90° =1.57 rad

t : Rotation time (s)



Safety Notice/ Rotary Cylinder/ Caution For Application

CHELIC

Calculation Example

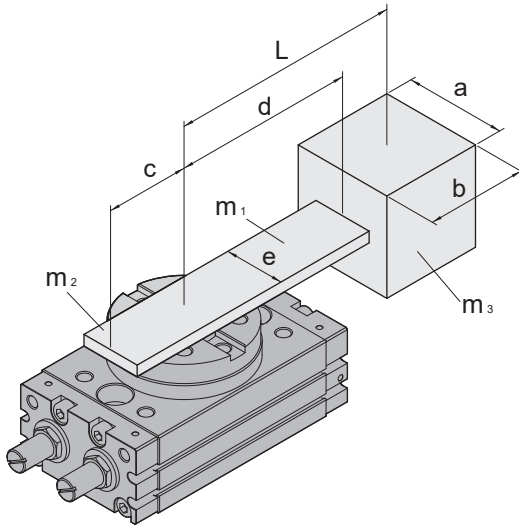

● Operating condition

a = 100 mm

b = 120 mm

c = 50 mm

d = 200 mm

e = 30 mm

L = 250 mm

m 1 = 1.5 kg

m 2 = 0.2 kg

m 3 = 5 kg

Rotation time = 0.8 s

Rotation angle = 90°

Selection type = RTB 70

● Using formula 4 to calculate the inertia of fixture

$$I_1 = 1.5 \times \frac{4 \times 0.2^2 + 0.03^2}{12} + 0.2 \times \frac{4 \times 0.05^2 + 0.03^2}{12}$$

$$= 0.02179 \text{ kg} \cdot \text{m}^2$$

● Using formula 7 to calculate the inertia of load

$$I_2 = 5 \times \frac{0.1^2 + 0.12^2}{12} + 5 \times 0.25^2$$

$$= 0.32266 \text{ kg} \cdot \text{m}^2$$

● The total inertia is $I_1 + I_2 = 0.34445 \text{ kg} \cdot \text{m}^2$

● Calculate angle speed

$$\omega = \frac{2 \times 1.57}{0.8}$$

$$= 3.925 \text{ rad/s}$$

● Calculate kinetic energy

$$E_1 = \frac{1}{2} \cdot 0.34445 \cdot 3.925^2$$

$$= 2.653 \text{ j}$$

● The kinetic energy value is bigger than RTB70 after calculating.

It needs to use RTB200 with shock absorber to match operating condition.

Model	Kinetic energy value allowing	
	With adjusting screw	With shock absorber
RTB10	0.007 J	0.039 J
RTB20	0.025 J	0.116 J
RTB30	0.048 J	0.116 J
RTB50	0.081 J	0.294 J
RTB70	0.24 J	1.1 J
RTB100	0.32 J	1.6 J
RTB200	0.56 J	2.9 J

RTM series Rotary Actuator

Product features

CHELIC

Internal structure



Specification

Item	Model (mm)	RTM10	RTM15	RTM20	RTM30	RTM40
Action		Double acting				
Fluid		Air				
Torque force	N · m	0.14	0.38	0.78	1.8	3.8
Bore size	mm	Ø 4	Ø 5	Ø 6	Ø 8	Ø 10
Rotation angle	°	90, 180, 270				
Port size		M5x0.8P				
Pressure range	Kgf/cm ² (kPa)	2~7 (200 ~ 700)				
Ambient and fluid temperature	°C	0~50				
Allowable kinetic energy	J	0.00015	0.001	0.003	0.02	0.04

Rotation angle

■ Rotation range $90^{\circ +4}_{0}$

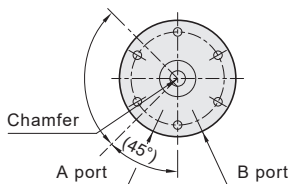

● 90°

■ Rotation range $180^{\circ +4}_{0}$

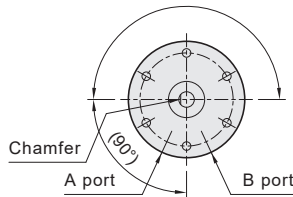

● 180°

■ Rotation range $270^{\circ +4}_{0}$

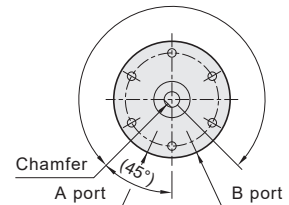

● 270°

Code of order

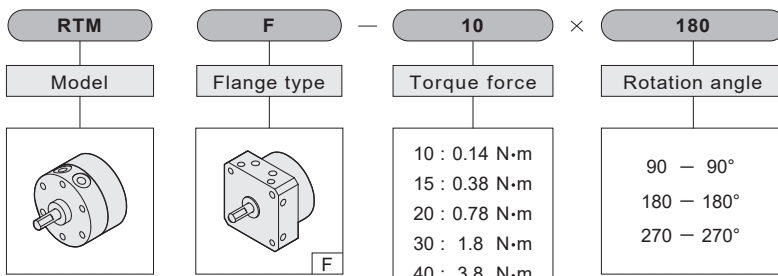

RTM series
Rotary cylinder

None: Standard
[F]: With front flange plate

RTM

RMF

RTB

RTBM

RTZB

RTP

RTH

RTU

RTM series Rotary Actuator

Product features

CHELIC

Mounting type

● RTM

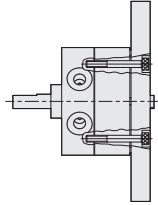

● Bottom mounting type

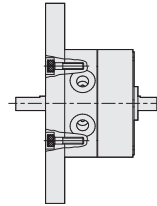

● Front mounting type

● RTM-F

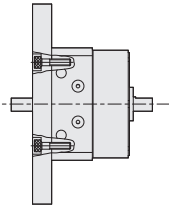

● Front flange type

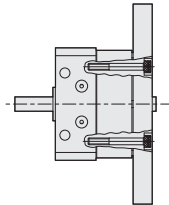

● Bottom flange type

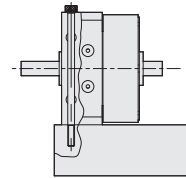

● Flange on side mounting

▶ Effective output

▼ RTM 10

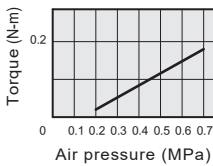

▼ RTM 15

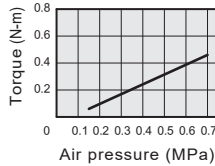

▼ RTM 20

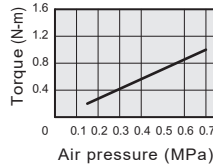

▼ RTM 30

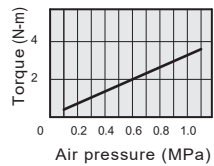

▼ RTM 40

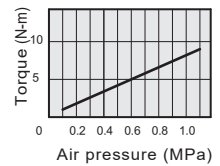

▶ Internal structure

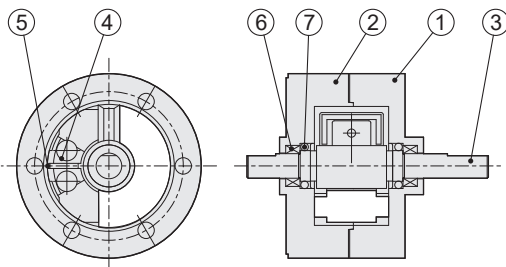

▶ Components and material list

NO	Item	Material
01	Front cover	Aluminum alloy
02	Rear cover	Aluminum alloy
03	Rotary unit shaft	Alloy Steel
04	Spacer block	POM
05	Spacer block O-ring	NBR
06	Bearing	Bearing steel
07	O-Ring	NBR

RTM series Rotary Actuator

Dimensions

CHELIC

RTM 10, 15, 20, 30, 40

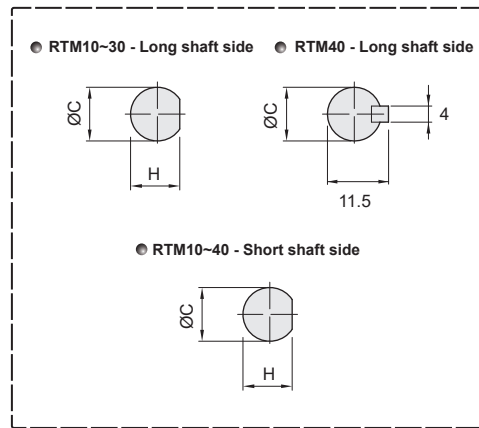
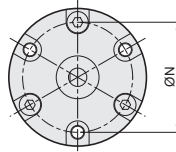
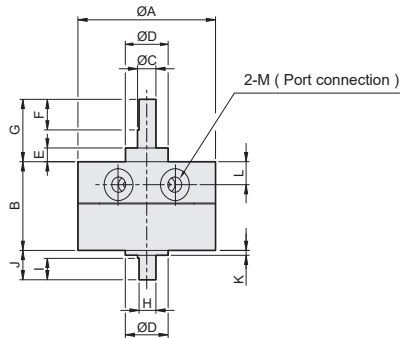
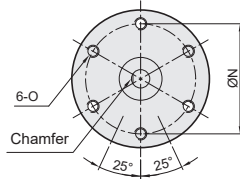

Dimension

Model	A	B	C	D	E	F	G	H	I	J	K	L	M	N	O
RTM10-90°	30	17	4	9	3	9	14	3.5	5	8	1	4.2	M5x0.8p	24	M3x0.5p
RTM10-180°															
RTM10-270°															
RTM15-90°	35	20.1	5	12	4	10	18	4.5	6	9	1.5	5	M5x0.8p	29	M3x0.5p
RTM15-180°															
RTM15-270°															
RTM20-90°	44	29.1	6	14	4.5	10	20.3	5.5	7	9.6	1.6	8.5	M5x0.8p	36	M4x0.7p
RTM20-180°															
RTM20-270°															
RTM30-90°	51	40	8	16	5	12	22	7.5	8	13	2	11	M5x0.8p	43	M5x0.8p
RTM30-180°															
RTM30-270°															
RTM40-90°	64	45	10	25	6.5	22	30	9	9	15	4.5	9.5	M5x0.8p	56	M5x0.8p
RTM40-180°															
RTM40-270°															

Weight

Model	RTM 10	RTM 15	RTM 20	RTM 30	RTM 40
Weight	28g	48g	112g	200g	342g

RTM

RMF

RTB

RTBM

RTZB

RTP

RTH

RTU

RTM series Rotary Actuator

Dimensions

CHELIC

RTM - F 10, 15, 20, 30, 40

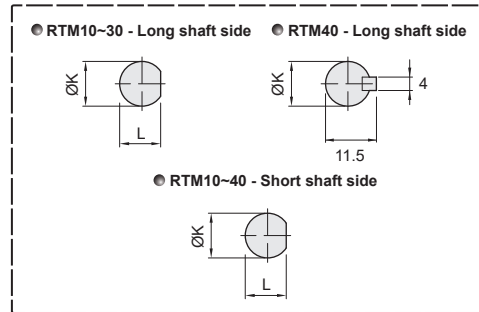
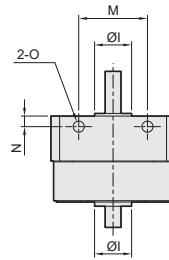
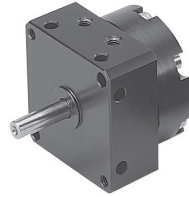
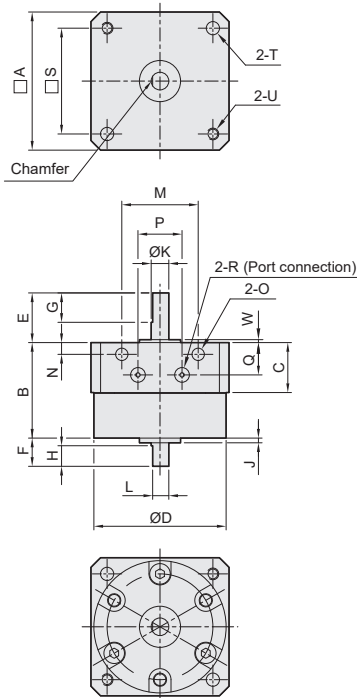

Dimension

Model	A	B	C	D	E	F	G	H	I	J	K	L	M	N	O	P	Q	R	S	T	U	V	W
RTM10-90°																							
RTM10-180°	31	22	13.3	30	14	8	9	5	9	1	4	3.5	17	3	3.5	10.5	9.2	M5x0.8p	25	3.5	M3x0.5p	24	1
RTM10-270°																							
RTM15-90°																							
RTM15-180°	36	25.7	15.5	35	18	9	10	6	12	1.5	5	4.5	21	3	3.5	10.5	10.5	M5x0.8p	29	3.5	M3x0.5p	29	1.5
RTM15-270°																							
RTM20-90°																							
RTM20-180°	44	33.6	19	44	20	10	10	7	14	1.6	6	5.5	26	4	4.2	15	13	M5x0.8p	36	4.5	M4x0.7p	36	1
RTM20-270°																							
RTM30-90°																							
RTM30-180°	52	47.5	27.2	51	22	13	12	8	16	2	8	7.5	29	4.5	5.5	13.5	18.5	M5x0.8p	42	5.5	M5x0.8p	43	2
RTM30-270°																							
RTM40-90°																							
RTM40-180°	64	53	30.4	64	30	15	22	9	25	4.5	10	9	38	5	5.5	19	14	M5x0.8p	52	5.5	M5x0.8p	56	3
RTM40-270°																							

Weight

Model	RTM10-F	RTM15-F	RTM20-F	RTM30-F	RTM40-F
Weight	41g	70g	138g	268g	438g

RTM series Rotary Actuator (Angle adjustment, Sensor switch)

Product features

CHELIC

Internal structure

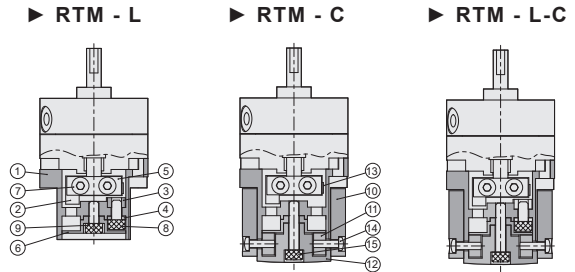
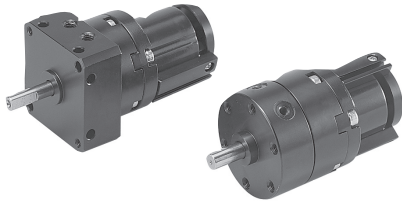

Components and material list

No.	Item	Material	No.	Item	Material
01	Sensor base	Alloy	09	Hexagon socket screw	Alloy steel
02	Sensor base block	Stainless steel	10	Sensor switch holder	Aluminum alloy
03	Angle location lump	Iron	11	Holder block	Aluminum alloy
04	Angle location slice	Iron	12	Rear cover	Aluminum alloy
05	Base block spacer	Stainless steel	13	Magnet	Rare earth metal
06	End cover	Aluminum	14	Round head screw	Alloy steel
07	Hexagon socket screw	Alloy steel	15	Hexagon socket screw	Alloy steel
08	Hexagon socket screw	Alloy steel			

Rotation angle

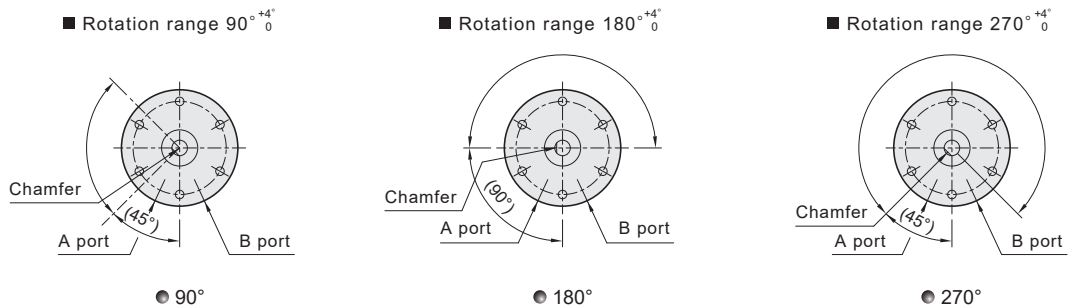

Code of order

RTM	F	10	×	180	-	L	-	C	1	-	SG	1
Model	Flange type	Torque force		Rotation angle		Adjustable angle		Sensor bracket			Sensor switch	
		10 : 0.14 N·m 15 : 0.38 N·m 20 : 0.81 N·m 30 : 1.8 N·m 40 : 3.8 N·m		90 - 90° 180 - 180° 270 - 270°								
RTM series Rotary cylinder	None : Standard [F] : With front flange plate							None : Standard [C] : Sensor bracket			[SG] : Sensor switch mark (CS-8G) [SGN] : Sensor switch mark (CS-8GN) [SGP] : Sensor switch mark (CS-8GP)	
								[2] : Number of Sensor bracket 1 = 1 PCS 2 = 2 PCS			[2] : Sensor switch number 1 = 1 PCS 2 = 2 PCS	

RTM series Rotary Actuator (Angle adjustment, Sensor switch)

Dimensions

CHELIC

RTM 10, 15, 20, 30, 40 - L

- Adjust angle implement

RTM10-30 - Long shaft type RTM40 - Long shaft type

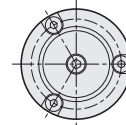
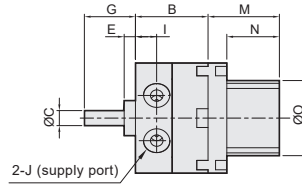
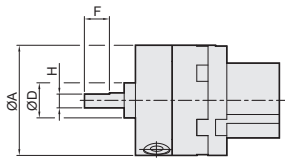
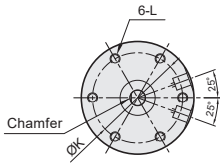
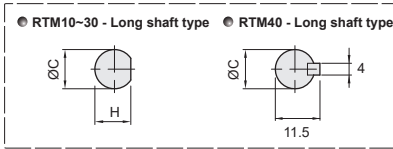

RTM 10, 15, 20, 30, 40 - C

- Sensor bracket

RTM10-30 - Long shaft type RTM40 - Long shaft type

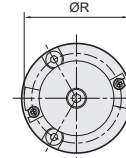
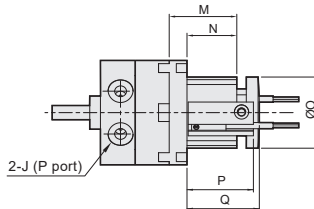
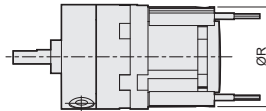
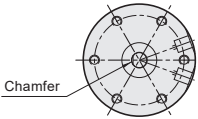
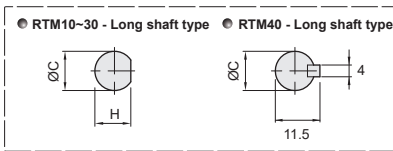

Dimension

Model	A	B	C	D	E	F	G	H	I	J	K	L	M	N	O	P	Q	R
RTM10-90°	30	17	4	9	3	9	14	3.5	4.2	M5x0.8p	24	M3x0.5p	24	18	18	23.3	24	29
RTM10-180°																		
RTM10-270°																		
RTM15-90°	35	20.1	5	12	4	10	18	4.5	5	M5x0.8p	29	M3x0.5p	28	22	24	27.3	29.5	34
RTM15-180°																		
RTM15-270°																		
RTM20-90°	44	29.1	6	14	4.5	10	20.3	5.5	8.5	M5x0.8p	36	M4x0.7p	28.5	21	30	28	30.5	42
RTM20-180°																		
RTM20-270°																		
RTM30-90°	51	40	8	16	5	12	22	7.5	11	M5x0.8p	43	M5x0.8p	32.5	24	34	30.8	34	47
RTM30-180°																		
RTM30-270°																		
RTM40-90°	64	45	10	25	6.5	22	30	9	9.5	M5x0.8p	56	M5x0.8p	34.5	26	34	33	36	47
RTM40-180°																		
RTM40-270°																		

Weight

Model	RTM 10	RTM 15	RTM 20	RTM 30	RTM 40
Weight	78g	116g	240g	390g	604g

RTM-F series Rotary Actuator (Angle adjustment, Sensor switch)

Dimensions

CHELIC

RTM-F 10, 15, 20, 30, 40 - L

- Adjust angle implement

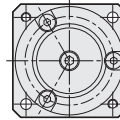
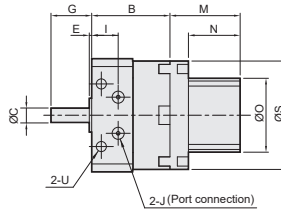
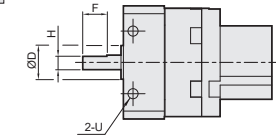
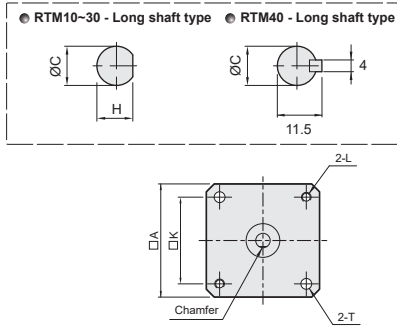

RTM-F 10, 15, 20, 30, 40 - C

- Sensor bracket

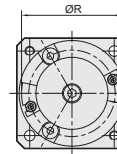
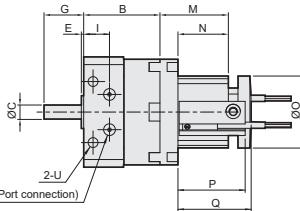
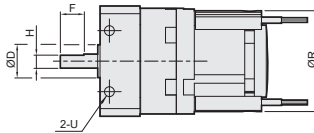
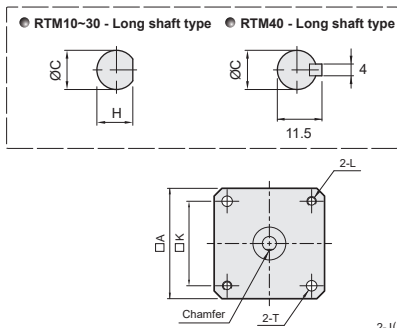

Dimension

Model	A	B	C	D	E	F	G	H	I	J	K	L	M	N	O	P	Q	R	S	T	U
RTM10-90°	31	22	4	9	1	9	14	3.5	9.2	M5x0.8p	25	M3x0.5p	24	18	18	23.3	24	29	30	3.5	3.5
RTM10-180°																					
RTM10-270°																					
RTM15-90°	36	25.7	5	12	1.5	10	18	4.5	10.5	M5x0.8p	29	M3x0.5p	28	22	24	27.3	29.5	34	35	3.5	3.5
RTM15-180°																					
RTM15-270°																					
RTM20-90°	44	33.6	6	14	1	10	20	5.5	13	M5x0.8p	36	M4x0.7p	28.5	21	30	28	30.5	42	44	4.5	4.2
RTM20-180°																					
RTM20-270°																					
RTM30-90°	52	47.5	8	16	2	12	22	7.5	18.5	M5x0.8p	42	M5x0.8p	32.5	24	34	30.8	34	47	51	5.5	5.5
RTM30-180°																					
RTM30-270°																					
RTM40-90°	64	53	10	25	3	22	30	9	14	M5x0.8p	52	M5x0.8p	34.5	26	34	33	36	47	64	5.5	5.5
RTM40-180°																					
RTM40-270°																					

Weight

Model	RTM10-F	RTM15-F	RTM20-F	RTM30-F	RTM40-F
Weight	91g	138g	266g	468g	700g

RTM

RMF

RTB

RTBM

RTZB

RTP

RTH

RTU

RTM series Rotary Actuator (Angle adjustment, Sensor switch)

Adjustment

CHELIC

Adjustment method of rotation angle

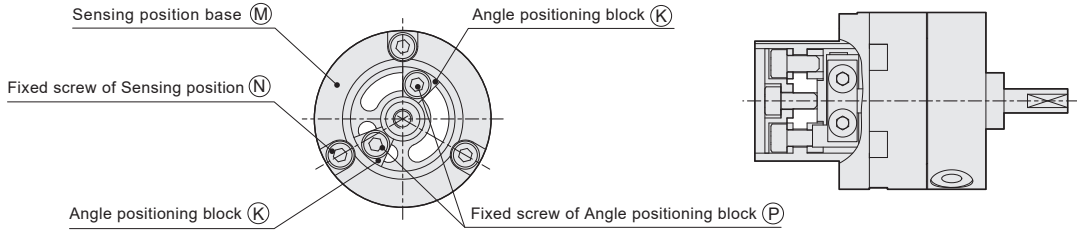

Method of adjustment :

- 1. Take out the Fixed screw of "Sensing position (N)", Adjust the "sense positioning base (M)" to desire setting position (A,B,C) and then tighten to secure.
- 2. Loosen Fixed screw of "Angle positioning block (P)" to allow the "Angle positioning block (K)" sliding on the slot (Please never loosen completely).
- 3. Slide the "Angle positioning block (K)" to desire angle and then tighten fixed screw.
- 4. Match the rotating shaft in order to achieve more accurate positioning.

Description of adjustment

There are three angle setting position (as showing figure - A,B,C below) for sensor positioning base of each model. The present range of adjustment is between internal angle position block inside the cylinder. Since there is limitation of accuracy of the internal angle positioning blocks inside the cylinder, if 90° and 180° accurate positioning is required, please adjust to 270°.

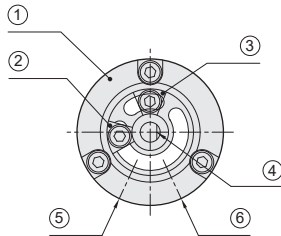

● Position- A

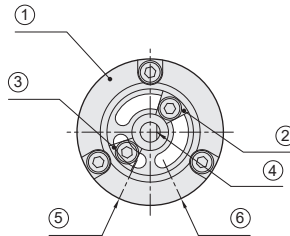

● Position- B

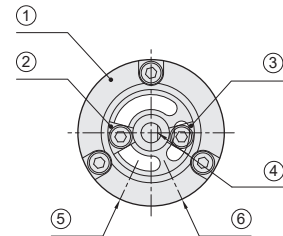

● Position- C

- ① Sensor positioning base
- ② Angle positioning block-1
- ③ Angle positioning block-2
- ④ Chamfer
- ⑤ A port
- ⑥ B port

- While using one group of angel positioning block and fixed to long slot side, the range of adjustable angle for each specification and listed as below:

Model	Position - A			Position - B			Position - C		
	90°	180°	270°	90°	180°	270°	90°	180°	270°
RTM-10									
RTM-15									
RTM-20	0°~90°	130°~180°	175°~225°	30°~90°	0°~180°	0°~250°	0°~10°	105°~180°	105°~270°
RTM-30									
RTM-40									

Note: 1. Home points are base on clockwise rotated shaft until contacting internal angle positioning blocks serving are 0°. The rotation range is the area while rotating and contact the angle position blocks again.

2. Specification of 90° is fixed by model A.

RTM series Rotary Actuator (Angle adjustment, Sensor switch)

Sensor switch operating range and the setting

CHELIC

Adjustment method of sensor switch position

Method of adjustment :

1. Loosen the Fixed screw of the holder (P) to allow sliding both sides.
2. Insert the sensor switch (S) into Holder (M) to flush with bottom, and then tighten the fixed screw (K).
3. Adjust the Holder (M) to desired angle, and then tighten the Fixed screw of the holder (P).

■ Sensor fixing position

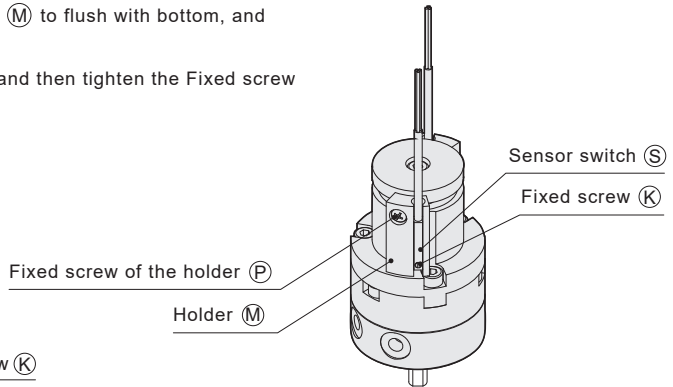
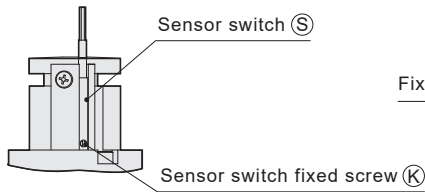

● Sensor switch position and adjustment method

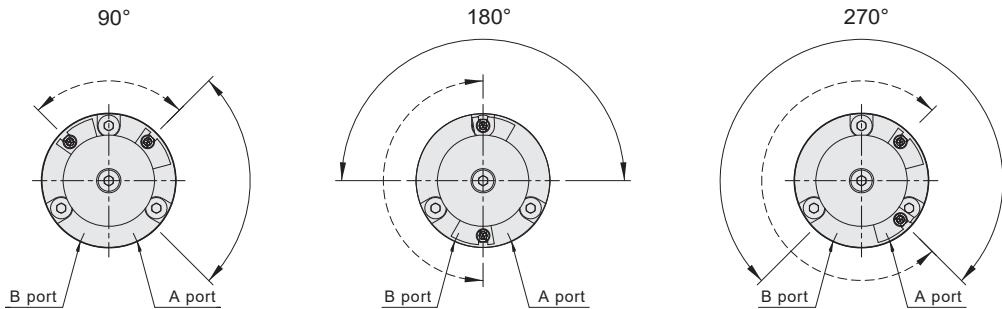

● Description of adjustment:

1. As illustrated in above figure, the solid line area indicate rotation area of shaft chamfer, dotted line indicate rotation area of magnet.
2. The rotation area of magnet represents valid adjustment range of the sensor fixing holder. The sensor switch is effective within this range.

● Sensor switch introduction

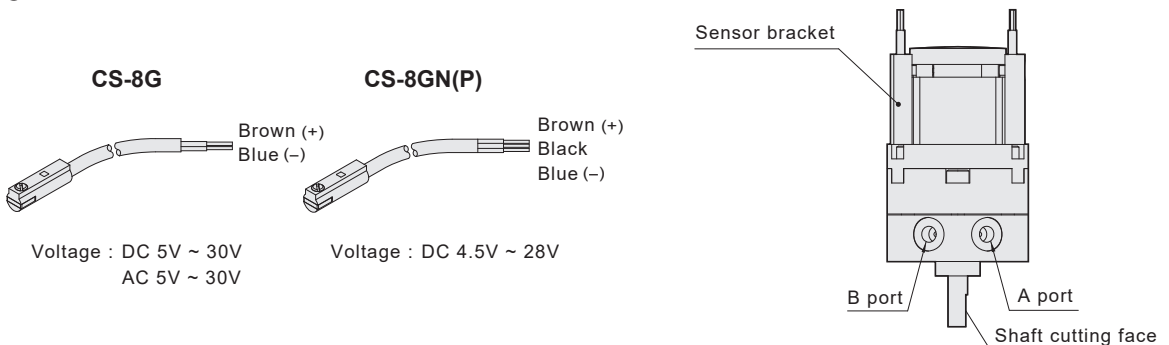

RTM

RMF

RTB

RTBM

RTZB

RTP

RTH

RTU

RTM 50, 63, 80, 100 Rotary Actuator

Product features

CHELIC

Internal structure

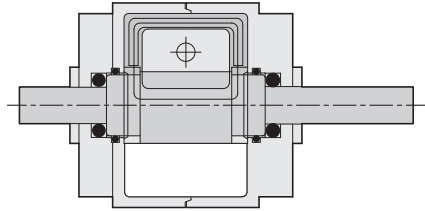
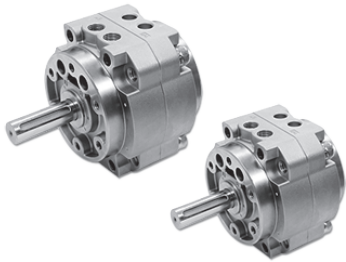

Specification

Item	Model (mm)	RTM50	RTM63	RTM80	RTM100
Action		Double acting			
Fluid		Air			
Torque force	N · m	5	10	18	35
Bore size	mm	Ø12	Ø15	Ø17	Ø25
Rotation angle	°	90, 180, 270			
Port size		PT 1/8		PT 1/4	
Pressure range	Kgf/cm ² (kPa)	1.5~7(150~700)			
Ambient and fluid temperature	°C	0~50			
Allowable kinetic energy	J	0.082	0.12	0.39	0.6

Rotation angle

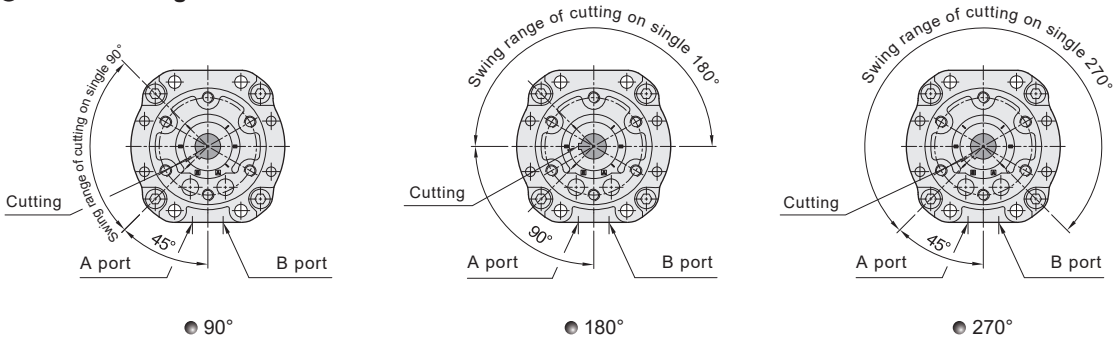

Code of order

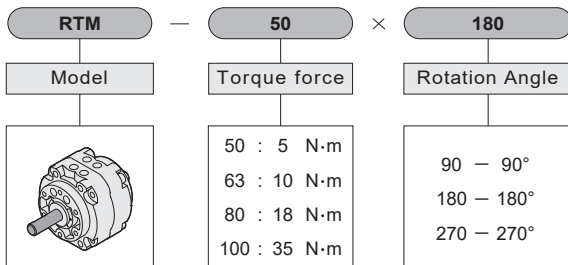

RTM series
Rotary cylinder

RTM 50, 63, 80, 100 Rotary Actuator

Product Features

CHELIC

Mounting type

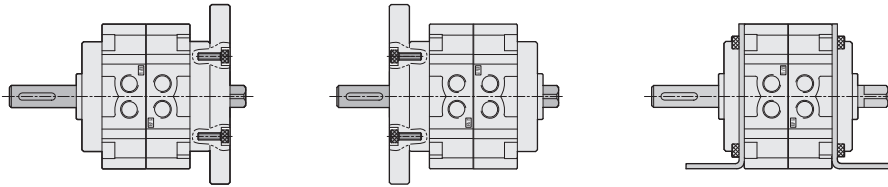

● Bottom mounting type

● Front mounting type

● Bracket mounting type

Effective output

● RTM 50

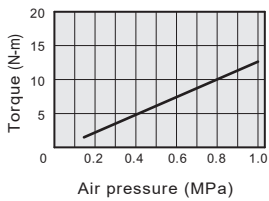

● RTM 63

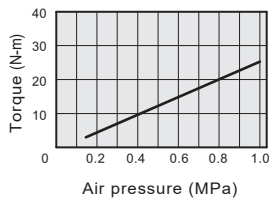

● RTM 80

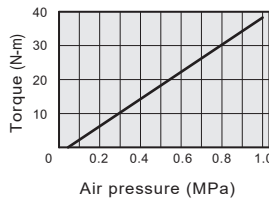

● RTM 100

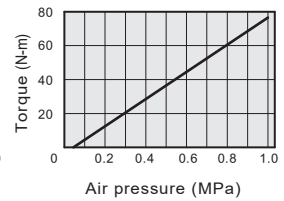

Internal structure

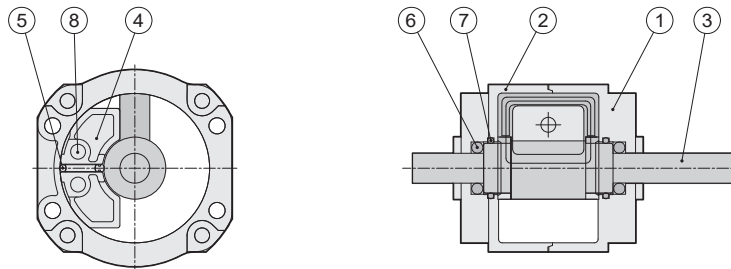

Material list

No.	Item	Material
01	Front cover	Aluminum alloy
02	Rear cover	Aluminum alloy
03	Rotary unit shaft	Alloy steel
04	Spacer block	Aluminum alloy
05	Spacer block O-ring	NBR
06	Bearing	Bearing steel
07	O-ring	NBR
08	Dowel pin	Bearing steel

RTM

RMF

RTB

RTBM

RTZB

RTP

RTH

RTU

RTM 50, 63, 80, 100 Rotary Actuator

Dimensions

CHELIC

RTM 50, 63, 80, 100

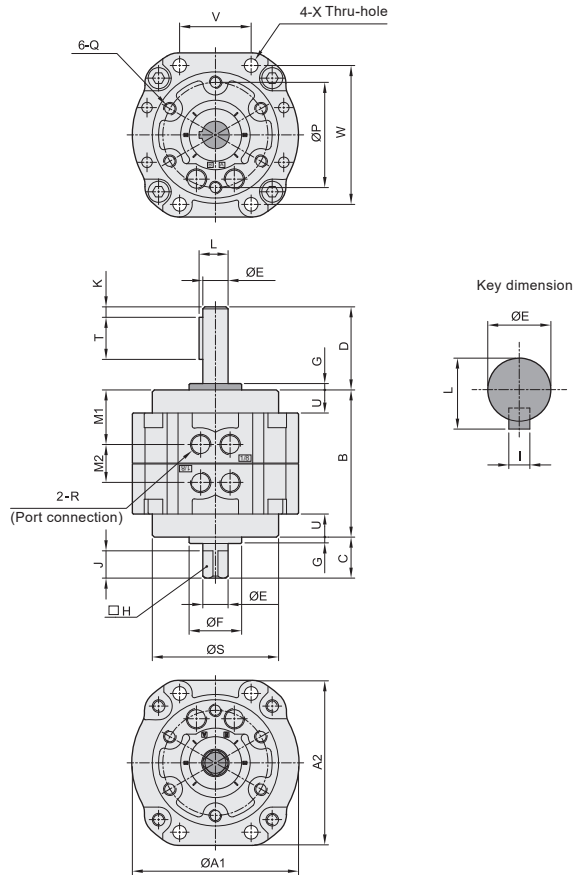

Dimension

Model	A1	A2	B	C	D	E	F	G	H	I	J	K	L	M1	M2	P	Q	R	S	T	U	V	W	ØX
RTM50-90°																								
RTM50-180°	79	78	70	19.5	39.5	12	25	3	10	4	13	5	13.5	26	18.2	50	M6X1.0P	RC1/8	60	20	11	34	66	6.5
RTM50-270°																								
RTM63-90°																								
RTM63-180°	98	98	80	21	45	15	28	3	12	5	14	5	17	28.9	22.2	60	M8X1.25P	RC1/8	75	25	14	39	83	9
RTM63-270°																								
RTM80-90°																								
RTM80-180°	110	110	90	23.5	53.5	17	30	3	13	5	16	5	19	30	30.2	70	M8X1.25P	RC1/4	88	41	15	48	94	9
RTM80-270°																								
RTM100-90°																								
RTM100-180°	140	140	103	30	65	25	45	4	19	7	22	5	28	35.4	32.2	80	M10X1.5P	RC1/4	108	40	11.5	60	120	11
RTM100-270°																								

Weight

Model	RTM 50	RTM 63	RTM 80	RTM 100
Weight	0.76 kg	1.29 kg	1.92 kg	3.56 kg

RTM 50, 63, 80, 100 Rotary Actuator (Angle adjustment, Sensor switch)

Product features

CHELIC

Internal structure

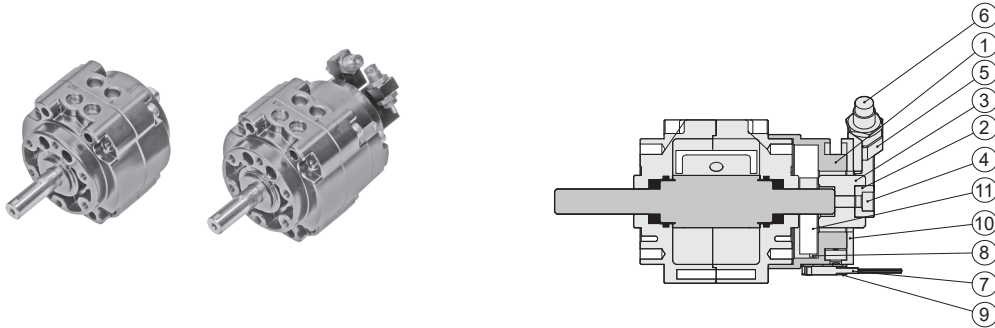

Components and Material list

No.	Item	Material	No.	Item	Material
01	Sensor base	Aluminum alloy	07	Sensor switch	—
02	Rocking arm	Stainless steel	08	Magnet	Rare earth metals
03	Rocking arm base	Stainless steel	09	Sensor switch base	Aluminum alloy
04	Arm screw	Alloy steel	10	Rear cover	Aluminum alloy
05	Angle adjustment base	Aluminum alloy	11	Magnet base	Aluminum alloy
06	Shock absorber	—			

Rotation angle

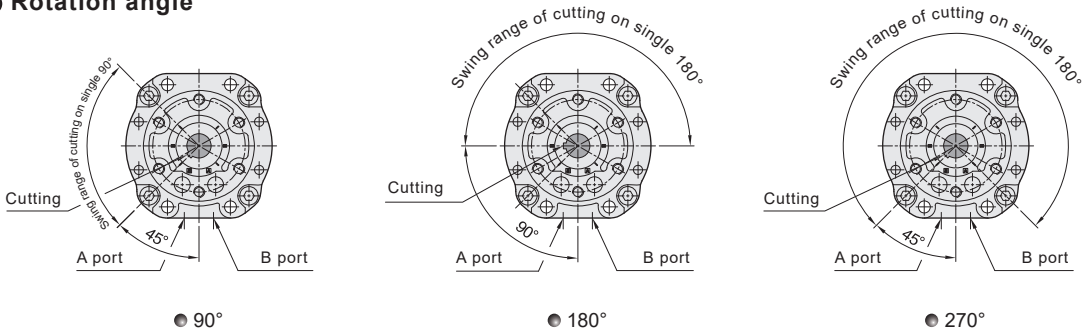

Code of order

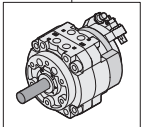
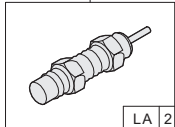
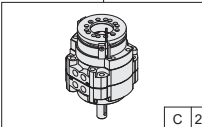
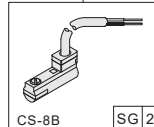
RTM	50	180	LA 1	C 1	SB 1
Model	Torque force	Rotation angle	Shock absorber	Sensor bracket	Sensor switch
	50 : 5 N·m 63 : 10 N·m 80 : 18 N·m 100 : 35 N·m	90 - 90° 180 - 180° 270 - 270°			
			LA 2	C 2	CS-8B SG 2

RTM series
Rotary cylinder

2 : Number of shock absorber
1 = 1 pcs
2 = 2 pcs

None: Standard
C : Sensor bracket mark
2 : Number of Sensor bracket
1 = 1 pcs
2 = 2 pcs

SB : sensor switch code (CS-8B)
2 : Number of sensor switch
1 = 1 pcs
2 = 2 pcs

RTM

RMF

RTB

RTBM

RTZB

RTP

RTH

RTU

RTM 50, 63, 80, 100 Rotary Actuator (Angle adjustment, Sensor switch)

Dimensions

CHELIC

RTM 50, 63, 80, 100

Angle adjustable and Sensor device

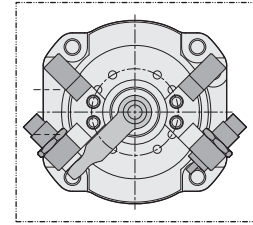
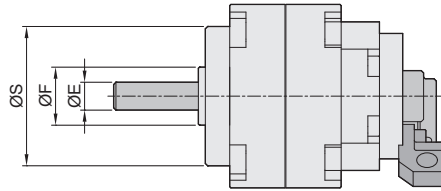

● RTM □ X90°

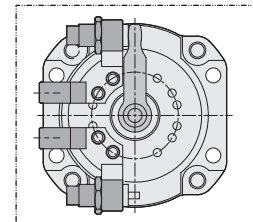
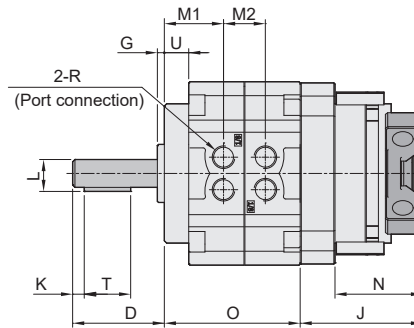

● RTM □ X180°

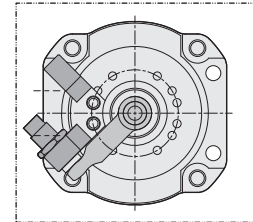
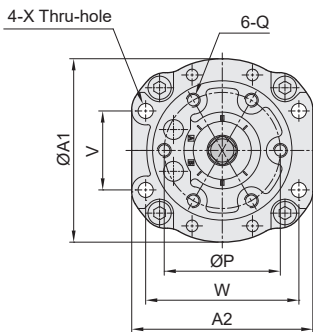

● RTM □ X270°

Key dimension

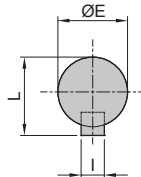

Dimension

Model	A1	A2	D	E	F	G	I	J	K	L	M1	M2	N	O	P	Q	R	S	T	U	V	W	ØX	
RTM50-90°																								
RTM50-180°	79	78	39.5	12	25	3	4	52.7	5	13.5	26	18	37.7	59	50	M6x1.0P	PT 1/8	60	20	11	34	66	6.5	
RTM50-270°																								
RTM63-90°																								
RTM63-180°	98	98	45	15	28	3	5	56.4	5	17	28.9	22.2	37.7	66	60	M8x1.25P	PT 1/8	75	25	14	39	83	9	
RTM63-270°																								
RTM80-90°																								
RTM80-180°	110	110	53.5	17	30	3	5	58.9	5	19	30	30	39.2	75	70	M8x1.25P	PT 1/4	88	41	15	48	94	9	
RTM80-270°																								
RTM100-90°																								
RTM100-180°	140	140	65	25	45	4	7	62.9	5	28	35.4	32.2	39.2	91.5	90	M10x1.5P	PT 1/4	108	40	11.5	60	120	11	
RTM100-270°																								

Weight

Model	RTM 50	RTM 63	RTM 80	RTM 100
Weight	1.1 kg	1.5 kg	2.3 kg	3.9 kg

RTM 50, 63, 80, 100 Rotary Actuator (Angle adjustment, Sensor switch)

Sensor switch operating range and the setting

CHELIC

Rotation angle and Rotation range

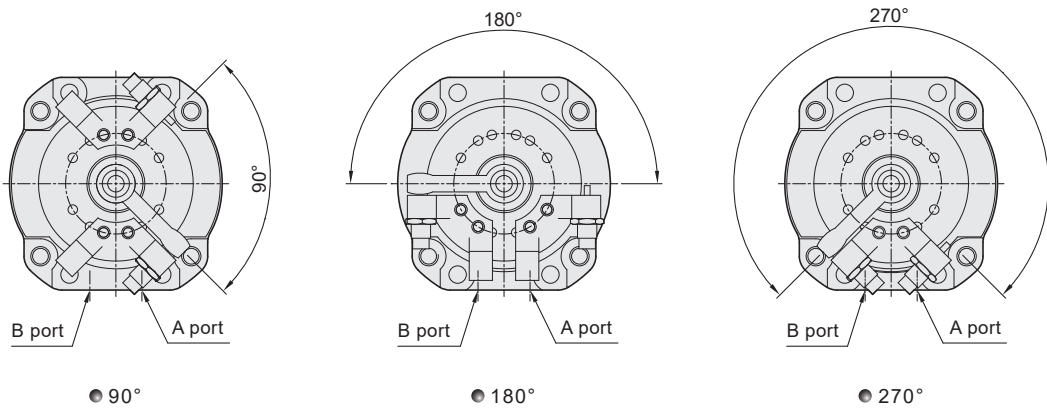

◎ Cushion position block shows as above figure. It could be choice shock absorber for rotating position and adjust angle. The angle range will be 0 ~ -10°

Sensor switch type

● Cushion position block include sensor switch hole, and it can assemble CS-8B sensor switch.

Method of adjustment :

- 1. Loosen the Fixed screw of the holder (P) to allow sliding both sides.
- 2. Insert the sensor switch (S) into Holder (M) to flush with bottom, and then tighten the fixed screw (K) .
- 3. Adjust the Holder (M) to desired angle, and then tighten the Fixed screw of the holder (P) .

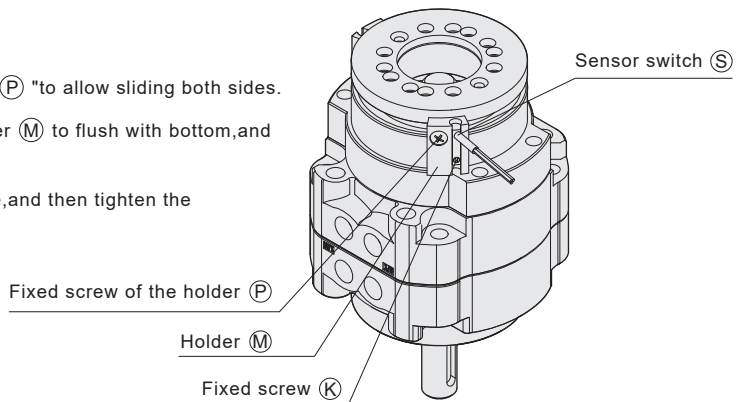

Sensor switch introduction

CS-8B

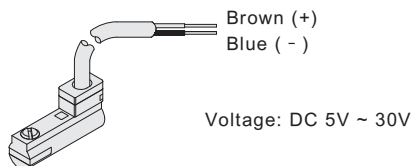

RTM

RMF

RTB

RTBM

RTZB

RTP

RTH

RTU