



# DANOTHERM™



## Brake resistors WHBSA

Specially designed for hybrid- and full electric bus & truck applications

- Small dimensions, high power density
- Fully welded construction (no gaskets in water circuit)
- Fully insulated, no external live parts
- IP 65
- Low thermal drift, 100ppm/K
- Low noise
- OEM version available

# WHBSA brake resistors for Bus & Truck applications

Dimensions (excl water connections) L = xxx	mm	WHBSA 100.xxx	WHBSA 150.xxx	WHBSA 200.xxx
Braking power	kW	19 - 32	38 - 160	63 - 253
L	mm	255-375	255 - 820	255 - 790
Length overall	mm	L+94	L+96	L+110
Width	mm	155	210	260
Height	mm	143	183	233
Diameter tank	mm	Ø114.3	Ø168.3	Ø219.1
DN size tank		DN100	DN150	DN200
Mounting holes (slotted holes)	mm	Ø10.5x15	Ø10.5x15	Ø10.5x15
Mounting holes distance	mm	L-83	L-83	L-83
Water connections acc. DIN 71550	mm	Ø32	Ø32	Ø50
Optional water connection	mm	Ø25	-	Ø32
Connection box material		AISI 304	AISI 304	AISI 304
Connection box size	mm	152x132x86	152x132x86	210x210x100
Drain valve ½"		optional	optional	optional
Cable glands and holes		optional	optional	optional
PT1000 sensor		standard	standard	standard

Table 1

## General

WHBSA water cooled brake resistors for bus & truck applications can withstand high brake-power loads. The resistor can withstand the power rating defined as heating power continuously without any degradation. For a 'down hill test' the resistor can endure more than double this power during 12 minutes. Over load power compared to heating power is a factor of 3.4 during 10 seconds and 3.1 during 15 seconds, with a cycle time of 60 seconds.

WHBSA brake resistors are offered in three diameter sizes and in different lengths. In total there are 16 different mechanical sizes. Ohmic values range depends on size/power.

The resistor elements expel the energy into the coolant medium very fast. A minimum overrun time of the coolant system of 30 seconds is advised. The minimum and maximum in- and outlet temperatures of the coolant medium depend on the properties of the coolant mixture. Recommended is a delta T of  $\leq 20^{\circ}\text{C}$ . For water/glycol mixture with system pressure of 1 bar the maximum coolant temperature is  $120^{\circ}\text{C}$ . The pressure drop between in- and outlet is between 0.2 and 0.5 bar. It depends on the coolant flow, the size of the water I/O connections and the used materials.



# Main characteristics

WHBSA	
<b>Electrical</b>	
Resistance tolerance	± 5%
Temperature coefficient	100 ppm/K
Maximum working voltage	1000VAC
Dielectric strength	3.5kV @ 50 Hz, 1 min.
Insulation resistance	≥ 20 MΩ @ 5000VDC
<b>Materials</b>	
Resistor elements	AISI 321
Connection box	AISI 304
Support and tank	AISI 304
Cable glands (optional)	nickel plated
Storage temperature (empty)	- 30°C to + 90°C
<b>Mechanical</b>	
Protection degree	IP65
<b>Cooling</b>	
Recommended ΔT [°C]	≤ 20
Operation pressure [bar]	≤ 3
Test pressure [bar]	4.5 @ 20°C for 1 hour
Pump overrun time [s]	30

Table 2

Power ratings are defined according to 4 different definitions.

1. Braking power is the power the resistor can endure during 12 minutes (down hill) test. This braking is done in exceptional situations and not more than 1x per day.
2. Max. power 10s/60s is the power the resistor can endure during 10 seconds every minute. The resistor should be cooled down before the first cycle runs.
3. Max. power 15s/60s is the power the resistor can endure during 15 seconds every minute. The resistor should be cooled down before the first cycle runs.
4. Heating power is the power the resistor can endure continuously. It is a reference to the power that can be used for heating up the passenger/driver compartment in the bus or truck (boiler function).

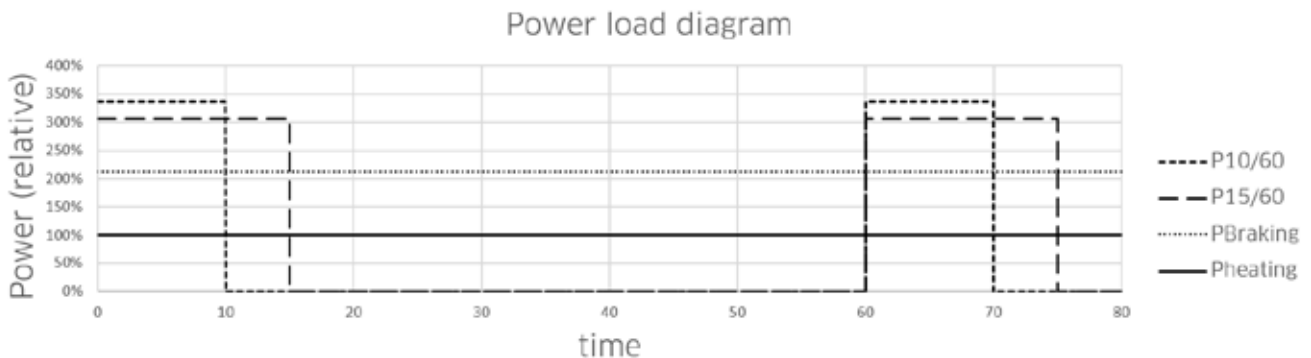

The braking power relates to the down-hill test. As a rule of thumb, for a 20 tons truck, 100kW braking power is required to perform this test. It is a brake test to keep the speed constant at 30km/h on a 4° (=7%) slope. It takes 12 minutes over a distance of 6km to come down from 418m height to 0m.

# WHBSA 100.xxx braking power 19-32kW

WHBSA 100.xxx L = xxx	unit mm	255	315	375
Braking power *	kW	19	26	32
Max. power 10s/60s	kW	30	41	50
Max. power 15s/60s	kW	28	37	46
Heating power **	kW	9	12	15
Minimum Ohmic value	Ω	0.4	0.5	0.6
Length (overall)	mm	L+94		
Width	mm	155		
Height	mm	143		
Diameter tank	mm	Ø114.3		
DN size		DN100		
Mounting holes (slotted)	mm	Ø10.5x15		
Mounting holes distance	mm	L-83		
Water hose connections	mm	Ø32 (optional Ø25)		
Box size	mm	152x132x86		
Weight (excl. water)	kg	14	16	17
Volume coolant	L	1.8	2.2	2.6
Water + 50% glycol flow @ braking power, ΔT=20°C	L/min	24	33	40
Water + 50% glycol flow @ heating power, ΔT=20°C	L/min	11	15	19

Mechanical dimensions WHBSA 100.xxx

Table 3

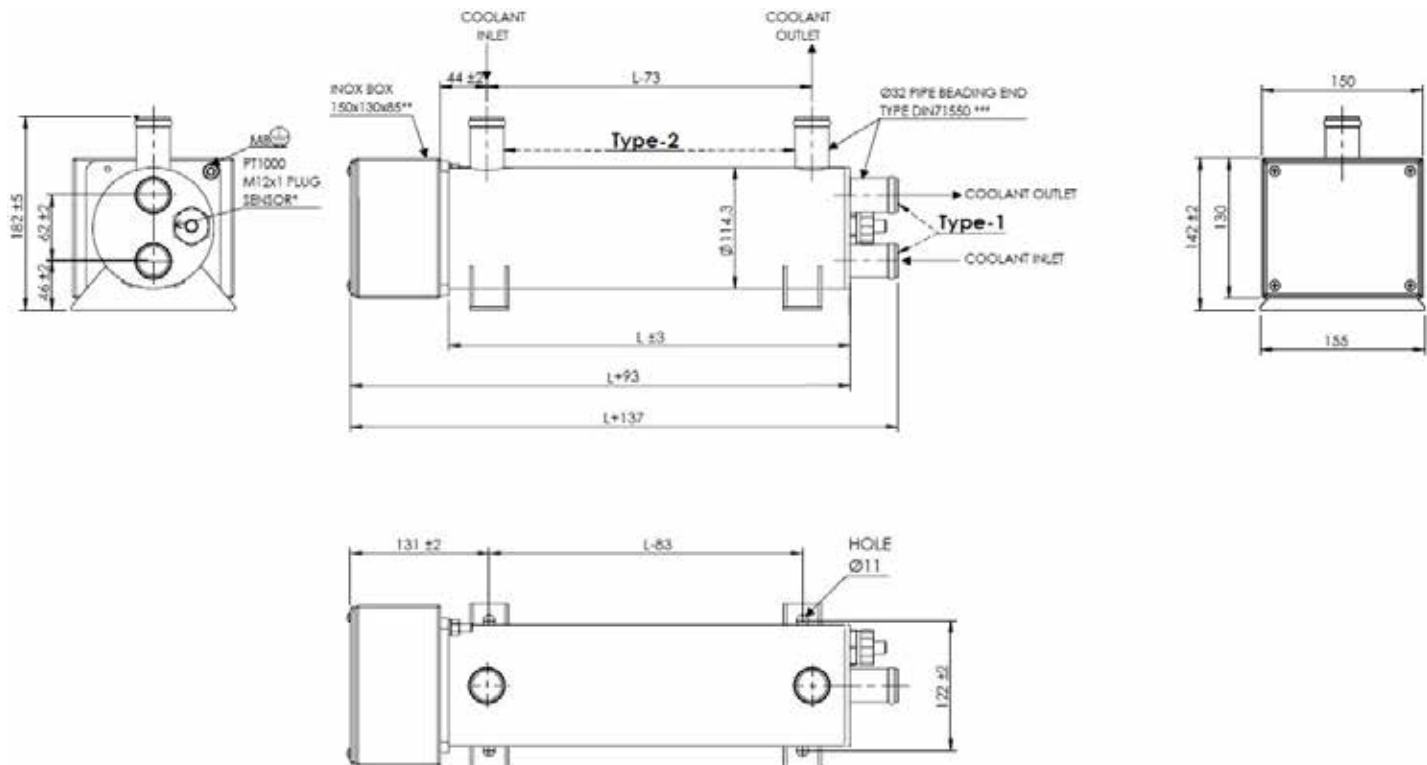

\* Power related to a 12 minutes down-hill test

\*\* Heating power can be used for acclimatizing the bus or truck

# WHBSA 150.xxx braking power 38-160kW

WHBSA 150.xxx L = xxx	unit	255	315	375	525	670	820
Braking power *	kW	38	51	64	96	128	160
Max. power 10s/60s	kW	61	81	102	152	201	253
Max. power 15s/60s	kW	55	74	93	138	183	230
Heating power **	kW	18	24	30	45	60	75
Minimum Ohmic value	$\Omega$	0.2	0.3	0.3	0.5	0.6	0.8
Length (overall)	mm	L+96					
Width	mm	210					
Height	mm	183					
Diameter tank	mm	$\varnothing 168.3$					
DN size		DN150					
Mounting holes (slotted)	mm	$\varnothing 10.5 \times 15$					
Mounting holes distance	mm	L-83					
Water hose connections	mm	$\varnothing 32$					
Box size	mm	152x132x86					
Weight (excl. water)	kg	20	22	24	29	34	39
Volume coolant	L	4	5	6	8.4	10.7	13
Water + 50% glycol flow @ braking power, $\Delta T=20^{\circ}\text{C}$	L/min	48	64	81	121	162	202
Water + 50% glycol flow @ heating power, $\Delta T=20^{\circ}\text{C}$	L/min	23	30	38	57	76	95

Mechanical dimensions WHBSA 150.xxx

Table 4

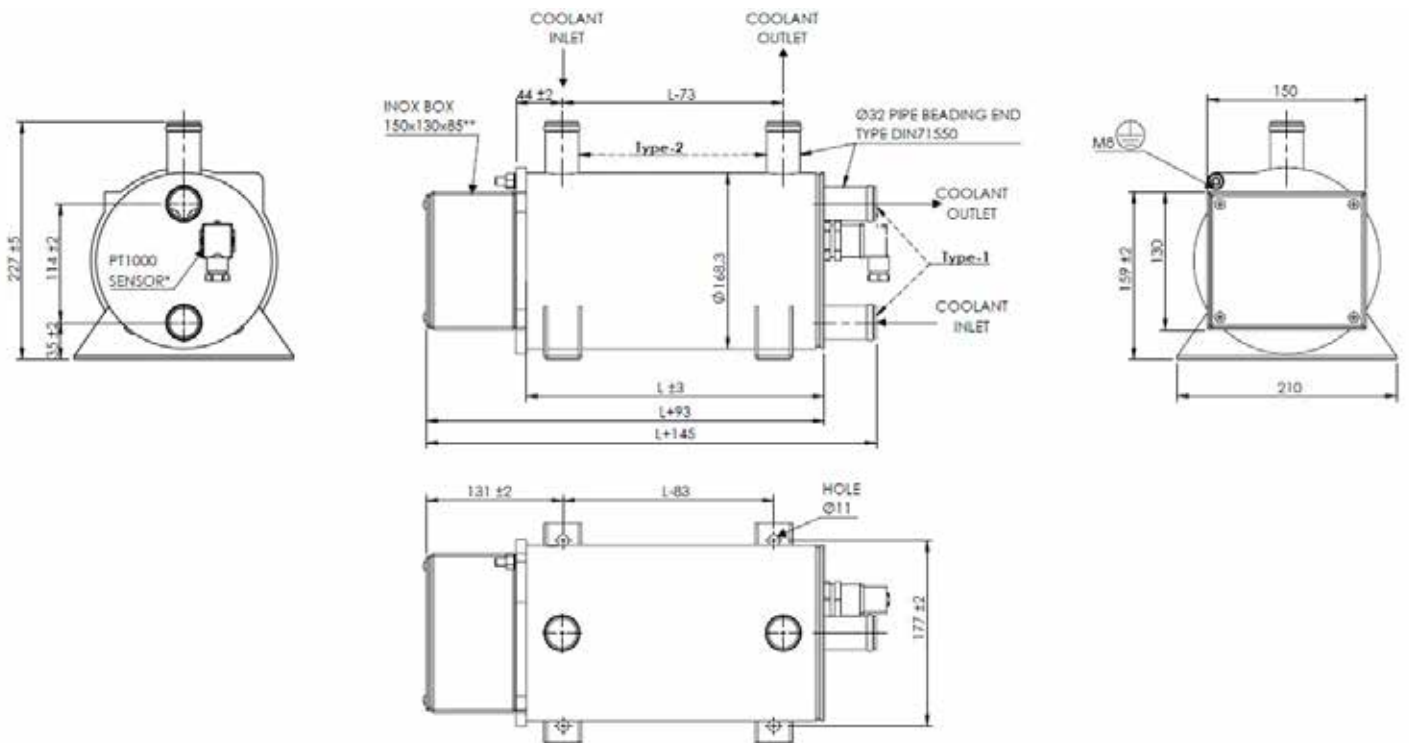

# WHBSA 200.xxx braking power 63-253kW

WHBSA 200.xxx L = xxx	unit mm	255	345	430	520	610	700	790
Braking power *	kW	63	95	126	158	189	221	253
Max. power 10s/60s	kW	100	150	199	250	299	349	400
Max. power 15s/60s	kW	91	137	181	227	272	318	364
Heating power **	kW	30	45	59	74	89	104	119
Minimum Ohmic value	Ω	0.1	0.2	0.2	0.3	0.3	0.4	0.5
Length (overall)	mm	L+110						
Width	mm	260						
Height	mm	233						
Diameter tank	mm	Ø219.1						
DN size		DN200						
Mounting holes (slotted)	mm	Ø10.5x15						
Mounting holes distance	mm	L-83						
Water hose connections	mm	Ø50 (optional Ø32)						
Box size	mm	210x210x100						
Weight (excl. water)	kg	22	27	32	36	41	46	51
Volume coolant	L	7	10	13	16	19	23	26
Water + 50% glycol flow @ braking power, ΔT=20°C	L/min	80	120	159	200	239	279	320
Water + 50% glycol flow @ heating power, ΔT=20°C	L/min	38	57	75	93	112	131	150

Mechanical dimensions WHBSA 200.xxx

Table 5

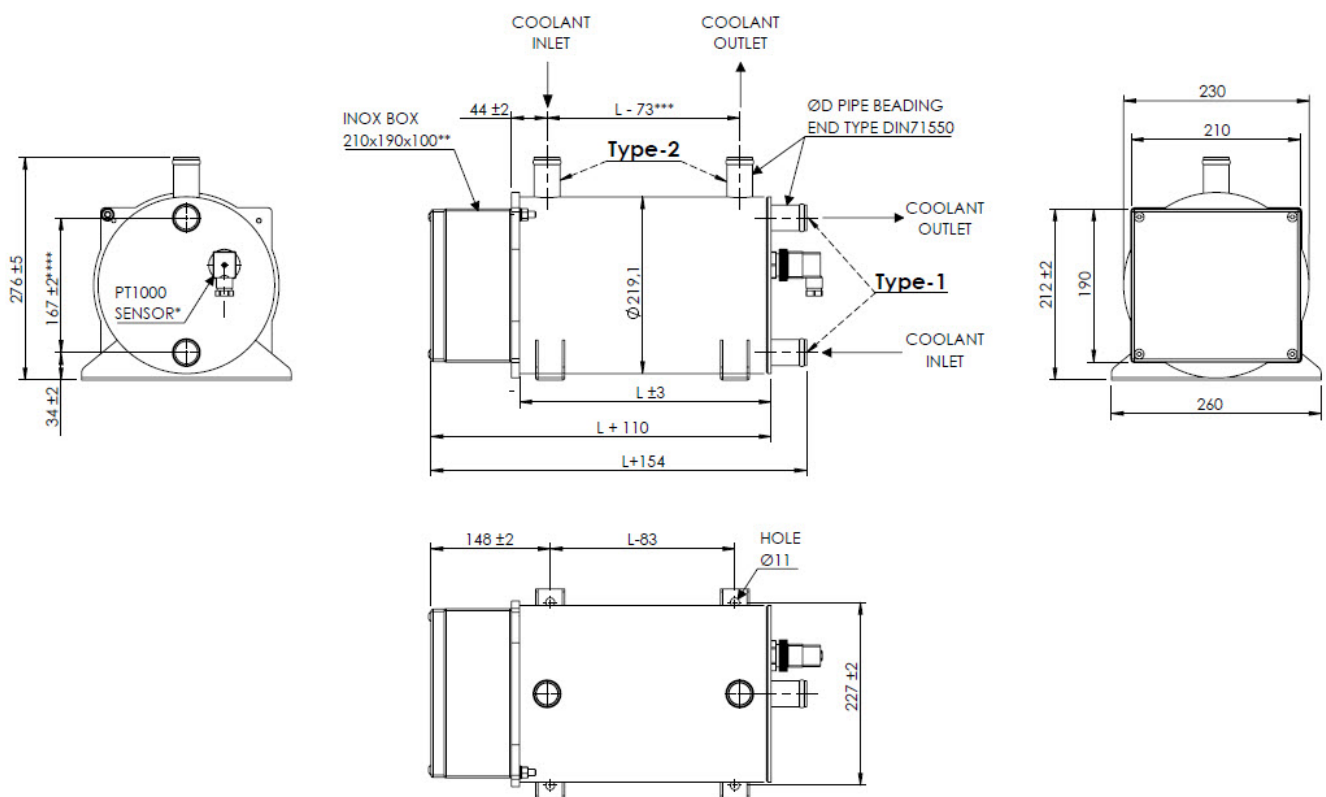

\* Power related to a 12 minutes down-hill test

\*\* Heating power, can be used for acclimatizing the bus or truck

# Coolant flow calculations

---

Calculation for water flow in Liters / minute:

$$\text{Water flow} = \frac{P * 60}{4.19 * \Delta T * 0.85}$$

With  $\Delta T$  of 20K;

$$\text{Water flow} \approx 0.84 * P$$

Water flow	Liters/minute
P	Power in [kW]
4.19	heat capacity of water [J/g.K]
60	1 minute, time in [s]
0.85	efficiency factor as not all coolant is participating in the heat exchange
$\Delta T$	Temperature difference between inlet and outlet in [°C] (recommended $\leq 20^\circ\text{C}$ )

The formula applies to 100% water. If the coolant is 50% water + 50% Glycol mixture the calculated flow needs to be multiplied with a factor of 1.5

$$\text{Water + glycol flow} \approx 1.5 * \text{Water flow}$$

## Cooling connections

The resistor has one water inlet + one outlet which can be axial (type 1) or radial (type 2) oriented. Both variants are depicted on the mechanical drawings. The size of the connections is  $\varnothing 32/50\text{mm}$  - DIN71550. Air- vent and drain plug can be fitted and are optional.

## Documentation

Available documents are:

- Datasheet
- Pressure Equipment Directive 2014/68/EU
- Mounting instruction
- Installation, operation and maintenance manual
- RoHS / REACH declaration
- Quality management system ISO9001:2015
- Quality management system ISO14001:2015

## Final acceptance test

All resistors are tested on:

- Outer dimensions
- Resistance value
- Insulation resistance
- Dielectric strength
- Pressure

A test report is issued for each resistor (batch).

## Auxiliary circuit

A PT100/1000 sensor is fitted near the resistor elements for water outlet temperature control.

Heating power levels from 18-75kW are in the range for acclimatizing driver and passengers compartment. Typical application is pre-heating a bus after/during charging cycle at the depot, half hour before start of the new shift. That way the bus leaves "warm" without having used any battery energy for it.

## Lifetime expectancy

The normal expected lifetime for these resistors is 20 year.

## End of life

The resistor does not contain any hazardous materials and can be recycled.



## Overview of the ALPHA resistor family (IP00-IP65)



Power: 60-410W	Power: 85W - 1.7kW	Power: 410W - 12kW	Power: 445W-15kW	Power: 860W-25kW
	9-150kJ @5s	25-550kJ @5s	80kJ-2.5MJ @5s	6.4kJ-1.1MJ @5s
- Applications	- Applications	- Applications	- Applications	- Applications
Charge / Discharge	High Pulse load	High Pulse load	High Pulse load	Short recovery time
Brake	Brake	Brake	Brake	Brake
Filter	Filter	Filter	Medium voltage	Filter
Charge / Discharge	Charge / High Pulse	Charge / High Pulse	Charge / High Pulse	High Pulse

## Other resistor types from Danotherm (IP00-IP65)



Multi purpose	Outdoor & Marine	Filter	Medium & HV	Filter & load
Power: 100W-5kW	Power: 1-500kW	Power: 4-200kW	Power: 500W->	Power: 5kW-1MW
Ceramic wirewound	Steel tube	Wirewound	Steel grid	Steel tube

Official Danotherm dealer



Danotherm Electric A/S  
 Naesbyvej 20  
 DK-2610 Roedovre  
 Denmark  
 CVR 1012 6061

DAN EN 18.5054  
 1MAR2021