

**Series ETA25PM – single/multiturn, programmable, analogue output, not redundant**
**Key features ETA25PM :**

- Measuring range 10° to max. 72000° (200 shaft revolutions)
- Programmable by the user using teach-in function. Programmable are the sense of rotation (CW/CCW) and the effective electrical angle [°]
- Programmable up to 10000 times
- Can also be used as a programmable singleturn rotary encoder
- Maximum rotation of the shaft in a voltage-free state without loss of the angle information +/-179°
- Factory programming (ex works): effective electrical angle of rotation 3600° (10 shaft revolutions), sense rotation CW
- Supply voltage: 9 to 30 VDC, 15 to 30 VDC
- Output signal: 4 to 20 mA, 0 to 5 V, 0 to 10 V

**Electrical data ETA25PM – multi/singleturn, programmable, analogue output, not redundant**

Effective electrical angle of rotation 1.)	0 to 10° - 0 to 72000° (max. 200 turns) Start point, endpoint and sense of rotation programmable by the customer. Ex works the angle is set to 3600°. For detecting absolute position >360° the sensor should not be turned more than ±179° without supply voltage.		
Independent linearity (best straight line) 1.)	±0.05% @ 3600°		
Absolute Linearity 1.)	±0.1% @ 3600°		
Output signal	0 to 5 V	0 to 10 V	4 to 20 mA
Resolution 1.)	12 Bit		
Update rate	3 ms		
Supply voltage	9 to 30 V	15 to 30 V	11 to 30 V
Power consumption (no load)	< 10 mA		< 14 mA
Output load	≥ 5 kOhm		≤ 500 Ohm
Insulation voltage 1.)	1000 VAC @ 50 Hz, 1 min		
Insulation resistance 1.)	2 MOhm @ 500 VDC, 1 min		
Max. number of programming cycles	10000		
MTTF (EN29500-2005-1)	224a		229a

1.) According IEC 60393

**Order Code ETA25PM – multi/singleturn, analogue output, not redundant**

Description	Selection: standard= <b>black/bold</b> , possible options= <i>grey/italic</i>					
<b>Series</b>	<b>ETA25PM</b>					
<b>Shaft diameter, shaft length:</b> Shaft diameter Ø 6 mm, shaft length 22 mm <i>Shaft diameter Ø 6.35 mm, shaft length 22 mm</i> <i>Custom shaft dimensions [mm] Ø ≤ 6.35 mm</i>		<b>6x22</b> <i>6,35x22</i> <i>XxXX</i>				
<b>Supply voltage / output signal:</b> VSUP=24 V (15 to 30 V) / OUT=0 to 10 V VSUP=24 V (9 to 30 V) / OUT=4 to 20 mA VSUP=24 V (9 to 30 V) / OUT=0 to 5 V			<b>2410</b> <b>2442</b> <b>2405</b>			
<b>Operational Torque:</b> Standard torque <i>Improved/medium torque</i>				- <i>MT</i>		
<b>Shaft sealing:</b> None <i>With shaft sealing</i>					- <i>D</i>	
<b>Electrical connection, cable length:</b> Flat ribbon cable, standard length 0.15 m <i>Flat ribbon cable with custom length [x,xx m]</i> Round cable, standard length 1 m <i>Round cable with custom length [x,xx m]</i>					<b>F0,15</b> <i>FX,XX</i> <b>R1,00</b> <i>RX,XX</i>	
<b>Anti-rotation pin, zero point definition:</b> <i>Pin A</i> <b>Pin B</b> <i>None (pins removed) (no zero point definition possible)</i>						<b>A</b> <b>B</b> -

**Order example ETA25PM**
**Requirement:**

Shaft Ø 6.00 mm, shaft length 22 mm, VSUP=24 V / OUT=0...5 V, sense of rotation CW, rotation angle ex works 3600° (can be programmed by customer), no shaft sealing, flat ribbon cable 1.00 m, anti-rotation pin B

**Example for order code:**

ETA25PM 6x22 2405 R1.00B

**Cable and pin assignment**

Function	Option F	Option R
DIR	Strand 1 (red)	orange
END	Strand 2	grün
START	Strand 3	gelb
VSUP	Strand 4	rot
OUT	Strand 5	braun
GND	Strand 6	schwarz

**For details on zero point definition see next page and page 28.**

**Programming device PRO for programming the encoder in the field**

**Key features programmer:**

- Programmable measuring range from 10° to max. 72000° (200 shaft revolutions)
- Programmable: sense of rotation (CW/CCW), effective electrical angle [°]
- Up to 10.000 programming cycles per rotary encoder

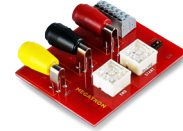

**Order number:**

135945

**Order code:**

Programmer Tool for ETA HTA PM

**Circuit for field-programming**

The programming guide is available for download on the MEGATRON web page <https://www.megatron.de/>

To program the encoder either the following circuit can be implemented, or one uses the programmer from MEGATRON.

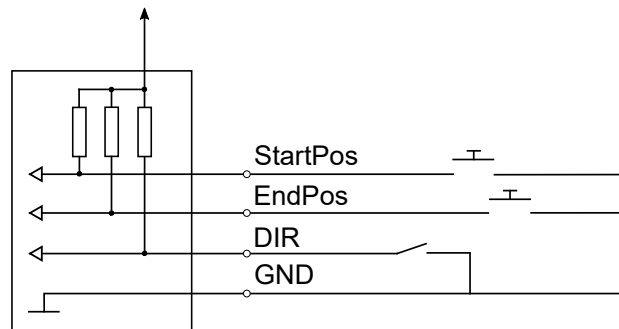

**Signal output function (factory programming only). Automatic function for inserting signal plateaus**

The function represents the relationship between the zero degree marking on the rotary encoder housing in dependency to the 0° position of the shaft and the resulting output signal in the state of delivery, when turning the shaft clockwise (sense of rotation CW). The effective electrical angle of rotation is 3600° ex works. Before and after the linearly rising output signal for 3600° the ETA25PM integrates automatically signal plateaus for a rotation angle of each 180° .

The following example shows the output signal pattern when actuating the shaft in the delivery state for 11 revolutions clockwise (sense of rotation CW), starting at the 0° position:

1. 10 rotations of the shaft clockwise 0° to 3600°, linearly increasing output signal 0% to 100% FS
2. 1/2 rotation of the shaft 180° (3600° to 3780°) signal plateau 100% FS
3. 1/2 rotation of the shaft 180° (3780° to 3960°) signal plateau 0% FS

The drawing shows the signal-amplitude function for 0 to 10V signal output

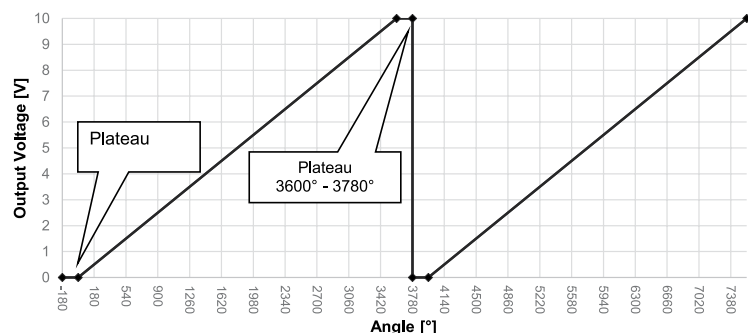

**Teach-In function – manual field programming**

When manual programming in the field using the teach-in function, the remaining angle for the next full revolution is divided equally into high and low. There are no further signal plateaus. Please see the programming guide on our website for more details.

Drilling pattern

Pattern of Drilling

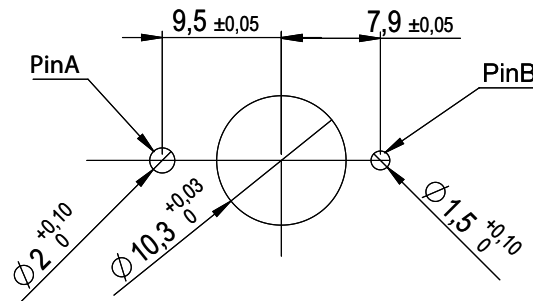

Either pin A or pin B must be chosen as anti-rotation pin. Please select by specifying the variant in the order code. The unused pin can be left out when drilling.

Drawings ETx25 – with solder holes (option L)

Option L

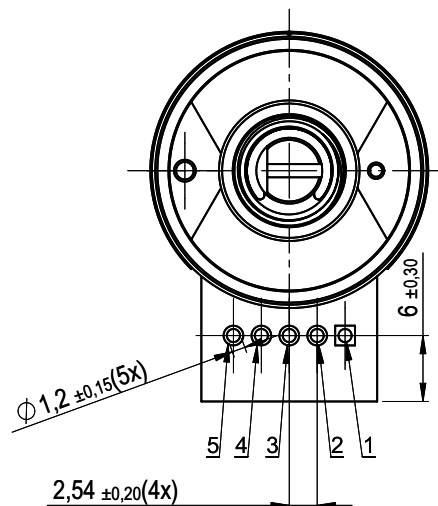
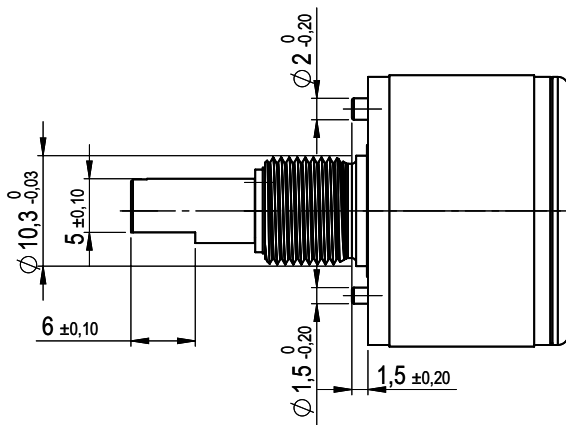
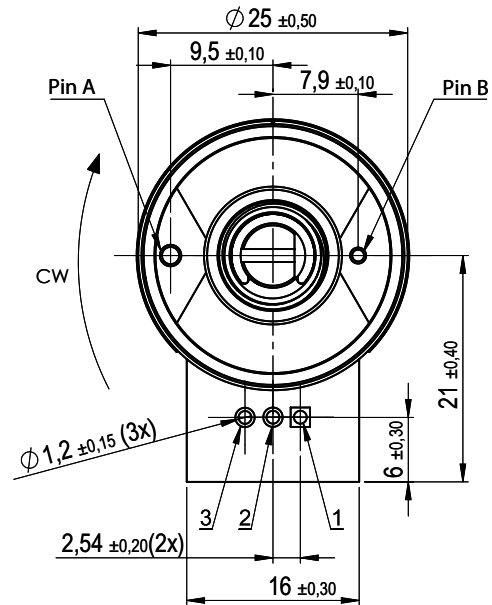
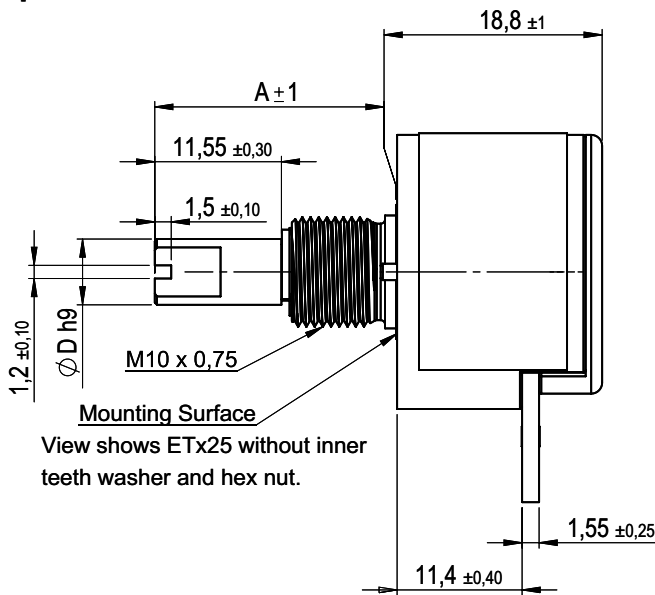

Standard shaft dimensions / tolerances

Shaft length A	22 +/- 1 mm
Shaft diameter D	6 h9 mm, 6.35 h9 mm
Shaft flattening (D-flat)	6 +/- 0.1 mm

All dimensions in mm

Drawings ETx25 – clamping terminals (option K) and cable versions (options R and F)

**Option K (clamping terminals)**

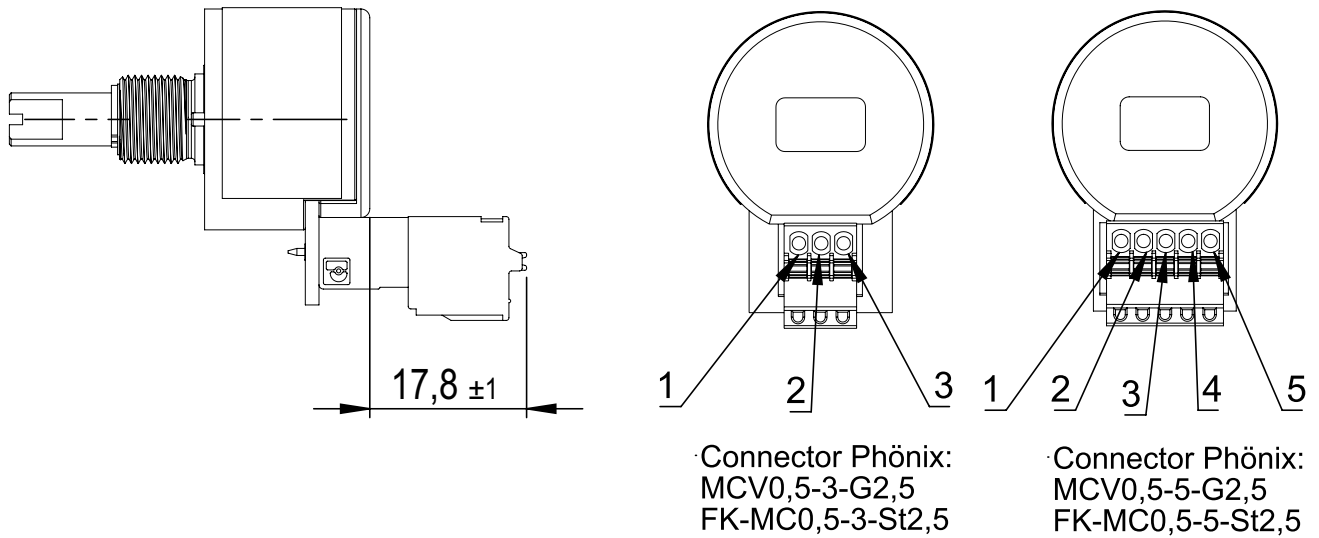

**Options F (flat ribbon cable) and R (round control cable)**

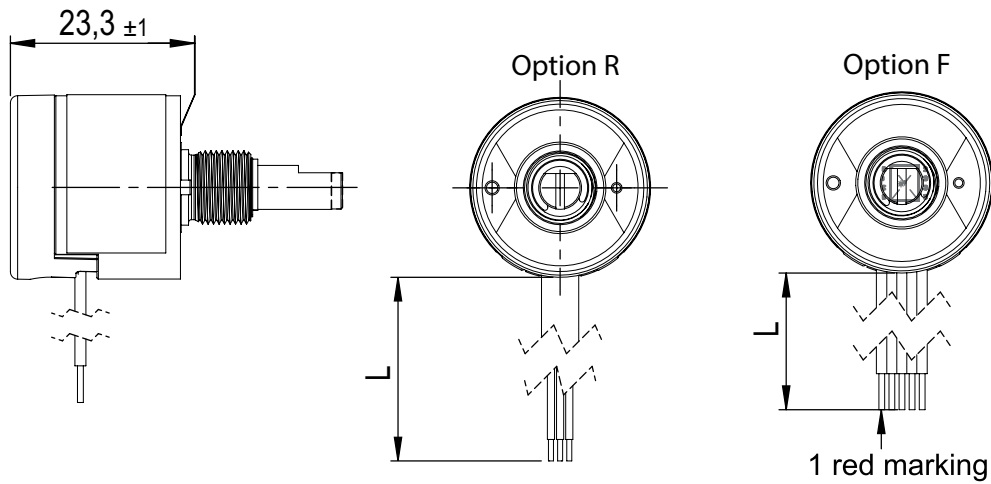

Cable specs for option F (flat ribbon cable) and R (round control cable)						
Option	Standard cable length L	Number of single strands (depends on electronics)	Cable sheath Ø or width	Single strands cross section	Allowed tolerance (L)	Minimum bending radius
R	Standard 1000 mm	3	4.3 mm	AWG26	-20 mm to +50 mm	3 x D Ø (D = cable sheath diameter Ø)
		6	5.2 mm			
		8	5.6 mm			
		12	6 mm	AWG28		
F	150 mm	3 to 12	ca. 1.25 per strand	AWG26	-20 mm to +25 mm	-

Cables without cable shield

(\*) Tolerances according IPC Association

Cable length tolerances – custom lengths	
Length L	Tolerance
≤ 0.3 m	+25 mm / -20 mm
> 0.3 m - 1.5 m	+50 mm / -20 mm
> 1.5 m - 3 m	+100 mm / -40 mm
> 3 m - 7.5 m	+150 mm / -60 mm

Cable harness length measured from sensor surface or soldering pad including connector.  
 Minimum cable length: 0.08 m (for round cable), 0.05 m for ribbon cable

Mechanical and environmental data, miscellaneous	
Mechanical angle of rotation 1.)	Endless or 320° (270°/180°/90°), ±5° with mechanical stop option
Lifetime 2.)	> 100 Mio. shaft rotation movements Option D: Sealing of the shaft is working ≥ 200 000 shaft rotation movements
Bearing	Sleeve bearing
Max. operational speed	100 rpm (< 1 min. 800 rpm)
Operational torque	0.1 ≤ M ≤ 0.6 Ncm (without shaft sealing) 0.3 ≤ M ≤ 1.3 Ncm (@RT, 10 rpm) (with increased torque)
Operating temperature range	Standard: -40 to +85 °C (cable fixed installed) Option TS: -25 to +70 °C
Storage temperature range	Standard: -40 to +105 °C Option TS: -40 to +90 °C (teach-In multiturn)
Protection grade (IEC 60529) front side	From shaft side: <ul style="list-style-type: none"> <li>▪ IP40 standard</li> <li>▪ IP55M (IP66S) with shaft sealing (option D)</li> </ul>
Protection grade (IEC 60529) rear side	<ul style="list-style-type: none"> <li>▪ IP50 Solder holes / clamping terminals (solder holes / connector excluded)</li> <li>▪ IP66 flat ribbon and round signal cable (cable ends excluded)</li> <li>▪ IP00 option TS (teach-in multiturn)</li> </ul>
Vibration (DIN EN 60068-2-6)	±1.5 mm / 30 g / 10 to 2000 Hz / 16 frequency cycles (3x4 h)
Shock (DIN EN 60068-2-27)	100 g / 6 ms / half sine (3x6 shocks)
Housing diameter	Ø 25 mm
Housing depth	see drawings
Shaft diameter	Standards: Ø 6 mm, Ø 6.35 mm Option: User defined shaft diameter [mm]
Max. radial load	1 N
Max. axial load	1 N
Mass (circa)	<ul style="list-style-type: none"> <li>▪ ca. 26 g (option L: solder lugs)</li> <li>▪ ca. 60 g (option R: cable, valid for 1 m only)</li> <li>▪ ca. 32 g (option F: flat ribbon cable, valid for 15 cm only)</li> <li>▪ ca. 27 g (option K: clamping terminals)</li> <li>▪ ca. 31 g (option TS: teach-In multiturn)</li> </ul>
Connection type	<ul style="list-style-type: none"> <li>▪ Solder lugs (option L)</li> <li>▪ Ribbon cable (option F)</li> <li>▪ Cable (option R)</li> <li>▪ Connector (option K)</li> </ul>
Connection position	Radial
Sensor mounting	Bushing via M10 x 0,75
Fastening parts included in delivery	Hex nut and tooth washer, if option D is ordered then an additional O-Ring is part of delivery as sealing between mounting panel and rotary encoder.
Fastening torque mounting nut	≤ 3 Nm
Material shaft	Stainless steel
Material housing	Plastic / Bronze

1.) According IEC 60393

2.) Determined by climatic conditions according to IEC 68-1, para. 5.3.1 without load collectives

**Immunity / Electrostatic Discharge / REACH / RoHS**

EN 61000-4-3 RF sine wave	Class A
EN 61000-4-6 Conducted sine wave	Class A
EN 61000-4-8 Power frequency magnetic fields	Class A
EN 61000-4-2 ESD 3.)	Class B
REACH Regulation (EC) 1907/2006 including the SVHC list	
RoHS Directive 2011/65/EU	

3.) Not tested for Option TS

**Definition of the zero position / anti-rotation pin**

**Output at the zero point:**

ETA25 (analogue outputs): Output signal 0% full scale (F. S.)  
 ETP25 (PWM output): duty cycle 10% (10% duty cycle)  
 ETS25 (serial output): Output signal 0% full scale (F. S.)  
 ETI25 (incremental output): The index signal is output (Z)

**Position of the zero position:**

Option anti-rotation pin A	Zero position when shaft flattening faces anti-rotation pin A
Option anti-rotation pin B	Zero position when shaft flattening faces anti-rotation pin A

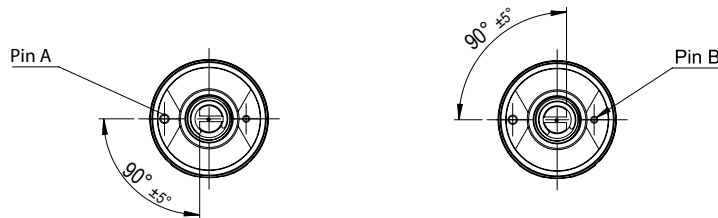

**Signal definition for custom rotation angles (without mechanical stop)**

Custom angles <360°

When programming the electrical angle of rotation of <360°, the remaining non-effective range of rotation is divided equally into high and low. Valid only for encoders without mechanical stop!

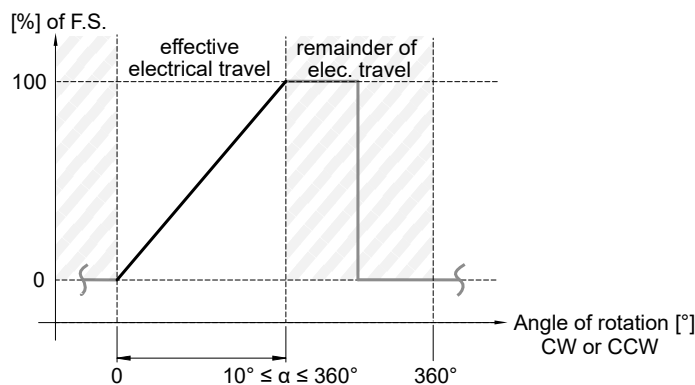



**Mechanical stop and centre detent for manual encoder applications**

- A mechanical stop limits the rotation to either 320°, 270°, 180° or 90° (±5°). Other angles are not available. Due to the mechanical tolerances (±5°), the effective electrical angle is reduced by 10°.
- Optionally a centre detent can be selected in addition to the mechanical stop. It enables the operator to e. g. feel the centre position when operating the encoder by hand
- The zero point definition for mechanical stop option differs from the standard zero point definition. Only drilling pattern B (pin B) is available. See the details below.

**Mechanical stop only: Relationship between mechanical and effective electrical angle of rotation**

Mechanical angle of rotation (±5°)	Effective electrical angle of rotation (±0.5°)
320°	310°
270°	260°
180°	170°
90°	80°

