

## Series HTI25K – singleturn, incremental output

### Key features HTI25K:

- Channels: A, B and index signal Z
- TTL or Open Collector electronics
- Maximum number of pulses per channel 20.000 pulses per revolution
- Option: ex works programmable number of pulses in pulse step width 1



## Electrical data HTI25K – singleturn, incremental output

Output Signal	TTL	Open Collector
Number of pulses	1 to 1024 ppr	1 to 20.000 ppr
Limit frequency	100 kHz	250 kHz
Switch-on delay	20 ms	6.3 ms
Supply voltage	3.3 or 5 VDC ±10%	4.8 to 42 V
Power consumption (no load)	≤ 15 mA	≤ 24 mA (for 5 V input)
Output load	≥ 5 kOhm	
Max. pull-up voltage	-	42 VDC
Max. pull-up current	-	600 mA
Insulation voltage 1.)	1000 VAC @ 50 Hz, 1 min	
Insulation resistance 1.)	2 MOhm @ 500 VDC, 1 min	
MTTF (SN29500-2005-1)	473a	1000a

1.) According to IEC 60393

## Output circuit HTI25K per channel

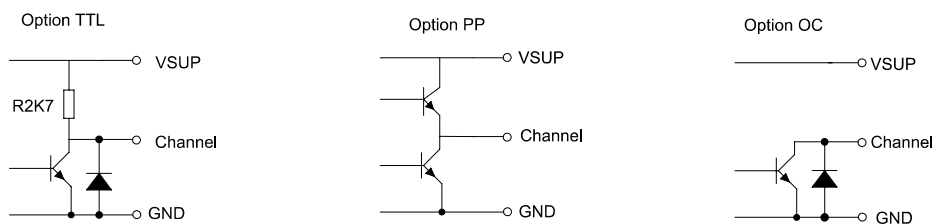

**For details on zero point definition and output programming see page 29.**

Order Code HTI25K – singleturn, incremental output				
Description	Selection: standard= <b>black/bold</b> , possible options= <i>grey/italic</i>			
<b>Series</b>	<b>HTI25K</b>			
<b>Number of pulses (ppr):</b>				
32		32		
64		64		
128		128		
256		256		
512		512		
<b>1024</b>		<b>1024</b>		
<i>User-defined number of pulses</i>		<i>XXXX</i>		
<b>Supply voltage / output signal:</b>			<b>05BZTTL</b>	
<b>VSUP=5 V ± 10% / OUT=TTL A, B, Z</b>			<b>BZOC</b>	
<b>VSUP=4.8 to 42 V / OUT=open collector A, B, Z</b>				
<b>Electrical connection, cable length:</b>				
<b>1 m round cable, axial</b>			<b>PG</b>	
<b>1 m round cable, radial</b>			<b>PGR</b>	
<b>Connector M8, radial*</b>			<b>M8R</b>	
<i>Round cable, customer-specific cable length [X,XX m], axial</i>			<i>PGX,XX</i>	
<i>Round cable, customer-specific cable length [X,XX m], radial</i>			<i>PGRX,XX</i>	
<b>Installation variant/drilling pattern:</b>				
<b>Variant S</b> (Pins for exact alignment optional and not included)				<b>S</b>
<b>Variant P</b> (pins pre-installed on the rotary encoder for precise alignment)				<b>P</b>

\* M8 axial connector variant not available

Order example HTI25K – singleturn, incremental output
<b>Requirement:</b> Shaft Ø 6.00 mm, number of pulses 1024 TTL output, VSUP=5 V/TTL, round cable 1 m
<b>Example for order code:</b> HTI25K 1024 05BZTTL PG

Cable and pin assignments – options 05BZTTL and BZOC			
Option M8(R), 8 pin		Option PG(R), round cable	
Pin-No.	Function	Wire colour	Function
Pin 1	VSUP	red	VSUP
Pin 2	GND	black	GND
Pin 3	A	brown	A
Pin 4	B	orange	B
Pin 5	Z	yellow	Z
Pin 6	n/c	green	n/c
Pin 7	n/c		
Pin 8	n/c		

Connector M8 – pin assignment for 8-pin connectors

Pin-Numbering of socket connector in the encoder housing

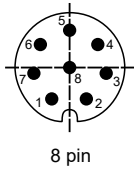

The orientation of the connector relative to the encoder housing is not defined and differs from one encoder to the next. When using angled connectors in combination with axial outlet, the orientation of the cable outlet is thus not defined.

If you need a defined orientation of the cable outlet, please choose our housings with radial cable outlet and use straight mating connectors.

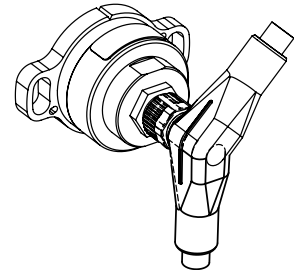

Orientation will vary when using angled connectors.

Signal details

Incremental signal output function

A, B, Z (version 05BZTTL)

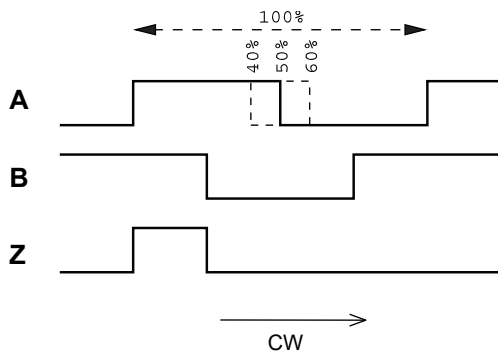

A, B, Z (version BZOC)

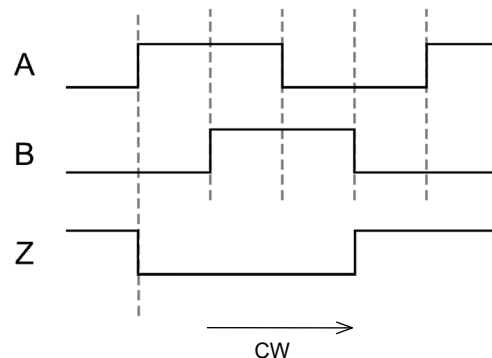

The percentage information describes the proportion of a pulse in dependency to the duration of one period

Drawings HTx25K – Drilling patterns S and P

**Dimensions Sensor head for Version with drilling pattern S**  
(pins optional, to be set by customer)

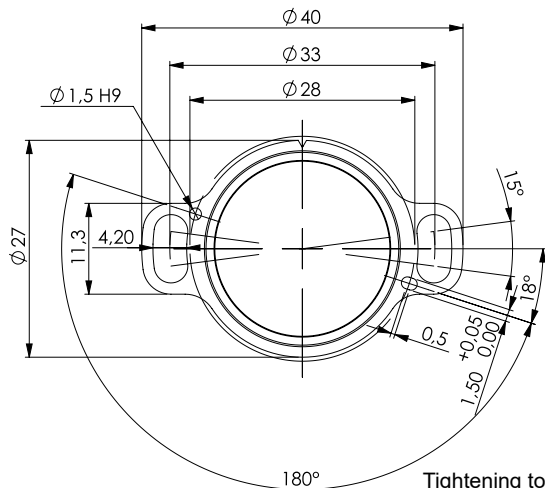

**Deviations of variant with drilling pattern P**  
(cylindrical pins part of the rotary encoder)

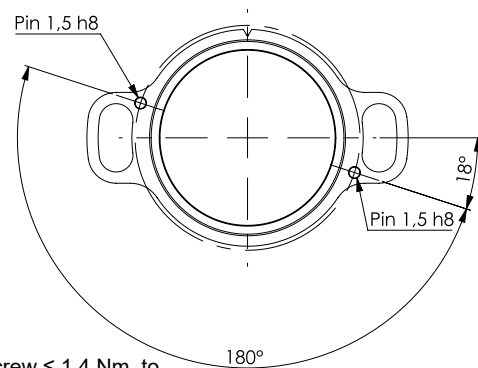

**Drilling pattern S**

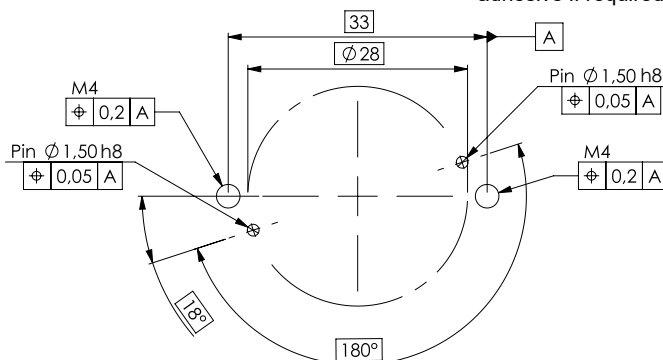

**Drilling pattern P**

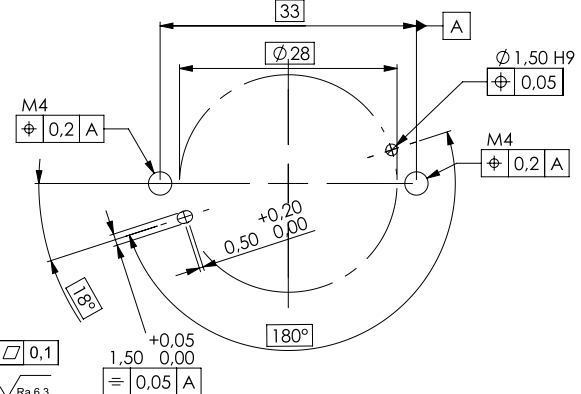

planarity of installation surface  $\square 0,1$   
roughness of installation surface  $\sqrt{Ra 6,3}$

All dimensions in mm

Accessories – Sealing ring



O-ring, part no. 133324  
DIN 3771-22x1-NBR 70

- For sealing between sensor front and mounting surface,
- Not included in delivery, please order separately

All dimensions in mm

Drawings HTx25K – Versions for drilling pattern S, magnet positioning

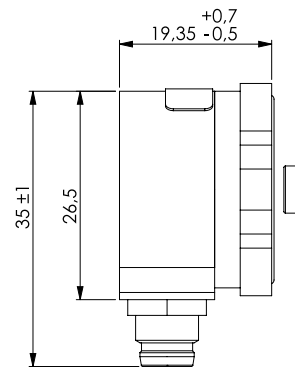
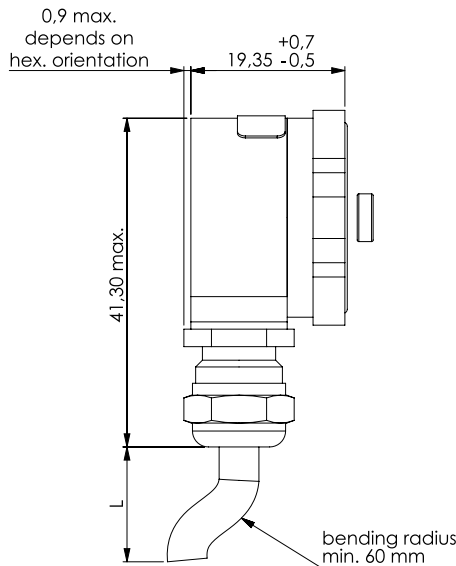
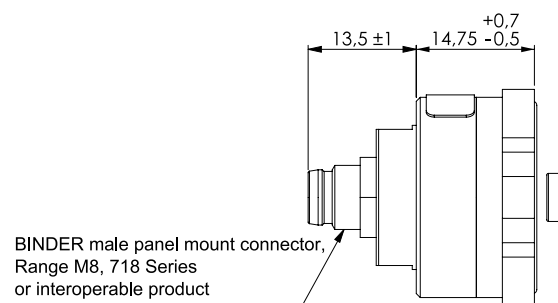
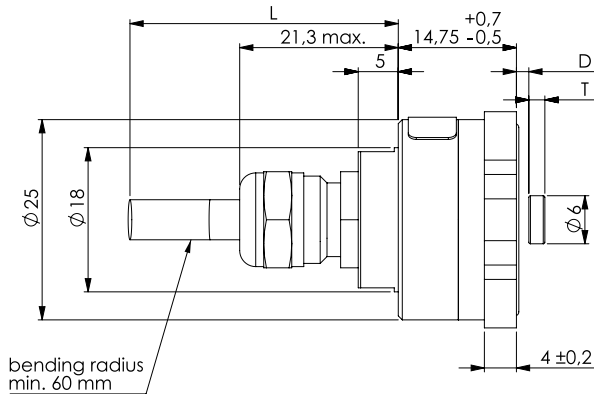

All dimensions in mm

Magnet selection and positioning for enclosed standard NdFeB magnets

**Important note:**

The correct mounting distance D as well as the correct positioning of the in relation to the central axis to the housing surface of the kiten-coder is mandatory for its correct function. The values below are not valid for other magnets (e. g. accessories).

Magnet thickness and distance from sensor surface		
Electronics	Thickness T of the magnet	Mounting distance D
Analogue singleturn not redundant, HTA25K, HTP25K, HTS25K (only SPI)	3 mm	1.50 +/- 0.15 mm
Serial, SPI, (HTS25K)	3 mm	1.50 +/- 0.15 mm
Serial, SSI, (HTS25K)	4 mm	0.50 +/- 0.15 mm
Analogue redundant, HTA25KX	2.5 mm	0.50 +/- 0.15 mm
Incremental, HTI25K	4 mm	0.50 +/- 0.15 mm
Analogue multi turn HTA25KPM	4 mm	1.00 +/- 0.15 mm

**Drawings HTx25K – Deviations for drilling pattern P**

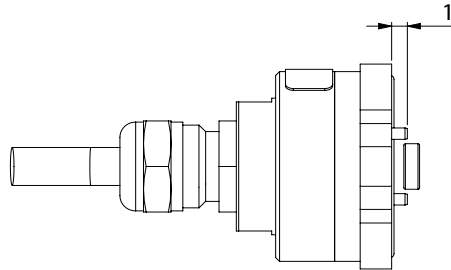

Pins/cylindrical pins are only pre-assembled if drilling hole pattern P is selected.  
Missing dimensions see drawings of the variants for hole pattern S.

**Drawings – Cable/connector exit direction for radial versions (M8R, PGR)**

view shows cable orientation

view shows connector position

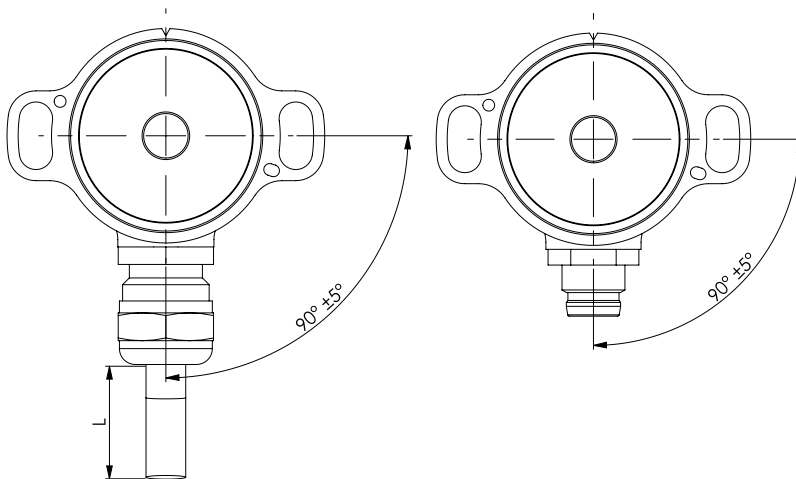

The orientation of the M8 connector pins relative to the encoder housing is not defined and differs from one encoder to the next. When using angled connectors in combination with axial outlet, the orientation of the cable outlet is thus not defined.

If you need a defined orientation of the cable outlet, please choose our housings with radial cable outlet and use straight mating connectors.

**Cable specs for option PG(R) (round control cable)**

Option	Standard cable length L	Number of single strands (depends on electronics)	Cable sheath Ø or width	Single strands cross section	Allowed tolerance (L)	Minimum bending radius
PG PGR	Standard 1000 mm	3		AWG26	-20 mm to +40 mm	10 x D Ø (D = cable sheath diameter Ø)
		6				
		8				
		10		AWG28		
		12				

Cables delivered with cable shield

(\*) Tolerances according IPC Association

**Cable length tolerances – custom lengths**

Length L	Tolerance
≤ 0.3 m	+25 mm / -20 mm
> 0.3 m - 1.5 m	+40 mm / -20 mm
> 1.5 m - 3 m	+100 mm / -40 mm
> 3 m - 7.5 m	+150 mm / -60 mm

Wire harness length measured from sensor face including connector. Minimum cable length: 0.08 m (for round cable). Please contact us for lengths > 3 m regarding handling and packaging.

**Mechanical and Environmental data**

Mechanical angle of rotation 1.)	Endless
Lifetime 2.)	Mechanically unlimited
Max. operational speed (with shaft sealing)	The maximum actuation speed is not limited mechanically. The maximum permissible actuation speed [rev./min] is calculated in relation to the resolution. For absolute encoders:
$rev./min. (@max. resolution) = \frac{1}{2^{Resolution\ in\ Bit} * Update\ rate\ in\ s} * 60s$	
For incremental encoders:	
$Max. rev./min. = \frac{Limit\ Frequency\ \frac{1}{s} * 60s}{Number\ of\ Pulses}$	
Operating temperature range	Option M8 (connector) <ul style="list-style-type: none"> <li>▪ -30 to +80°C</li> </ul> Option PG (cable gland incl. cable) <ul style="list-style-type: none"> <li>▪ -30 to +85°C cable fixed</li> <li>▪ -10 to +85°C cable in movement</li> </ul>
Storage temperature range	-30 to +105°C
Protection grade (IEC 60529) front side	IP67
Protection grade (IEC 60529) rear side	Option PG: IP68 (cable ends excluded) Option M8: IP67 (when mated with IP67 type M8 cable)
Vibration (DIN EN 60068-2-64:2008 + A1: 2019)	±1.5 mm / 30 g / 10 to 2000 Hz / 16 frequency cycles (3x4 h)
Shock (DIN EN 60068-2-27)	400 m/s <sup>2</sup> / 6 ms / half sine (100±5) shocks
Housing diameter	Ø 25 mm
Housing depth	In dependency to the electrical connection position: <ul style="list-style-type: none"> <li>▪ axial 28.25 mm (variant with M8 connector)</li> <li>▪ radial 19.35 mm (variant with M8 connector)</li> </ul>
Shaft diameter	No limitation (customer side)
Masse (zirka)	HTx25K with connector M8(R), 19 g HTx25K with cable gland and 1 m signal cable PG(R), 48 g

1.) According IEC 60393

2.) Determined by climatic conditions according to IEC 68-1, para. 5.3.1 without load collectives

**Immunity / Electrostatic Discharge / REACH / RoHS**

EN 61000-4-3 RF sine wave	Class A
EN 61000-4-6 Conducted sine wave	Class A
EN 61000-4-8 Power frequency magnetic fields	Class A
EN 61000-4-2 ESD	Class B
REACH Regulation (EC) 1907/2006 including the SVHC list	
RoHS Directive 2011/65/EU	

**Mechanical and environmental data, miscellaneous**

Sensor mounting	<p>Standard mounting is done by using M4 screws. A rotation of +/- 7.5° is possible to find the zero point in the application when installing the magnet.</p> <p>Alternatively, it is possible to align the rotary encoder exactly to the magnet using cylindrical pins (1.5 mm) in the application (a rotation is then not possible, however).</p> <p>There are two variants/two drilling patterns to choose from:</p> <ul style="list-style-type: none"> <li>▪ Variant S (standard): Cylindrical pins are installed by the customer in the application and the rotary encoder is attached and fixed using M4 screws</li> <li>▪ Variant P: Cylindrical pins are pre-installed on the rotary encoder. The drillings for the pins must be implemented on the mounting position in the application. This variant is suitable, for example, for mounting on thin sheet metal.</li> </ul>
Mounting hardware included	<p>none</p> <p>(Note: With hole pattern P, the cylinder pins are already fixed on the rotary encoder)</p>
Fastening torque per screw for fastening of the rotary encoder	<p>≤ 1.4 Nm (M4 screws, thread tensile strength class 5.6)</p> <p>For screw securing, the use of a medium-strength thread securing adhesive is recommended</p>
Material shaft	Stainless steel
Material housing	Aluminium
Material cable gland (PG)	Stainless steel
Material connector M8	CuZn nickel-plated

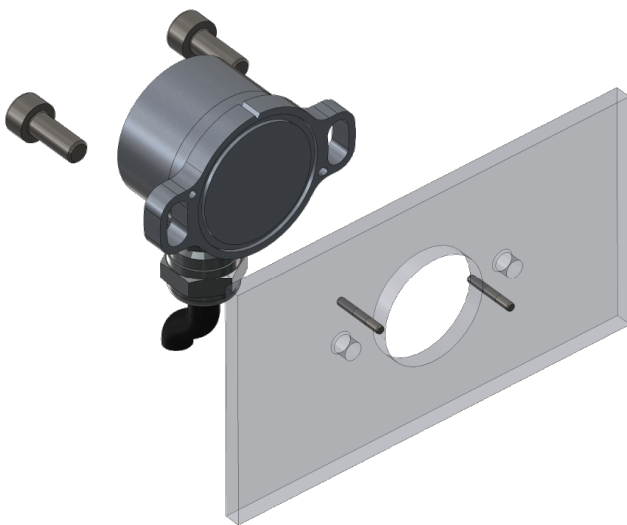

**Mounting example of the variant for drilling pattern S**  
 Mount using 2 M4 screws, optional exact alignment using 2 cylindrical pins h8 1.5 (e.g. ISO 2338 B)  
 (screws and pins not included)

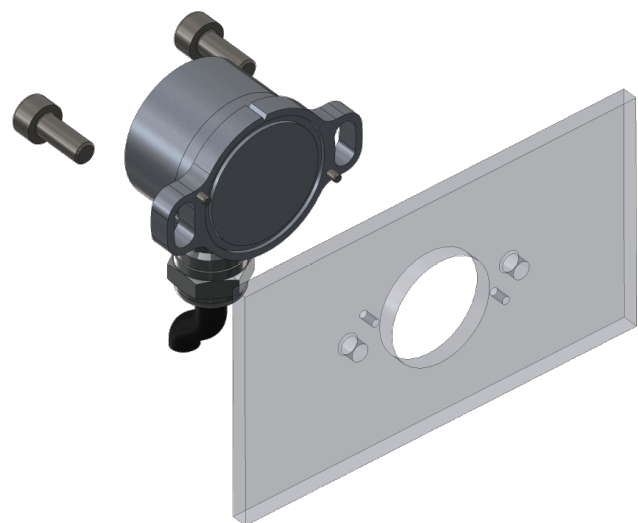

**Mounting example of the variant for drilling pattern P:**  
 Mount using 2 M4 screws, exact alignment is ensured using cylindrical pins h8 1.5 pre-assembled at encoder  
 (screws not included)



**Definition of the zero position**

**Output at the zero point:**

- HTA25K (analogue outputs): Output signal 0% full scale (F. S.)
- HTP25K (PWM output): duty cycle 10% (10% duty cycle)
- HTS25K (serial output): Output signal 0% full scale (F. S.)
- HTI25K (incremental output): The index signal is output (Z)

The position of the zero position cannot be mechanically defined due to the rotationally symmetrical magnet.  
The sense of rotation is defined when looking at the flat front of the rotary encoder:

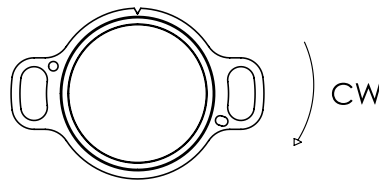

**Signal definition for custom rotation angles**

Custom angles <360°

When programming the electrical angle of rotation of <360°, the remaining non-effective range of rotation is divided equally into high and low.

