



Table for standard stroke

Tube I.D.	Stroke (inch)	Long stroke (inch)	Max. stroke (inch)
20: 3/4"	1, 2, 3, 4, 5, 6, 8	8.01~14	48
25: 1"	1, 2, 3, 4, 5, 6, 8, 10, 12	12.01~16	
32: 1 1/4"		12.01~18	
40: 1 1/2"		12.01~32	
50: 2"		12.01~48	
63: 2 1/2"		12.01~19	19

* Intermediate stroke are available, please contact us.

Specification

Model	MCCN						
Acting type	Double acting						
Tube I.D. (inch)	3/4"	1"	1 1/4"	1 1/2"	2"	2 1/2"	
Port size	NPT1/8				NPT1/4		
Medium	Air						
Max. operating perssure	1 MPa						
Min. operating perssure	0.05 MPa						
Proof pressure	1.5 MPa						
Lubrication	Not required						
Ambient temperature	-5~+60°C (No freezing)						
Available speed range	50~500 mm/sec						
Max. allowable kinetic energy (J)	Cushion pad	0.07	0.10	0.17	0.3	0.5	0.85
	Cushion air	0.09	0.14	0.23	0.45	0.85	1.23
Sensor switch	RCM (Please refer to page 8-16)						
Sensor switch band	BMG20	BMG25	BMG32	BMG40	BMG50	BMG63	

Order example

MCCN — 11 — 40 — 0425M — A

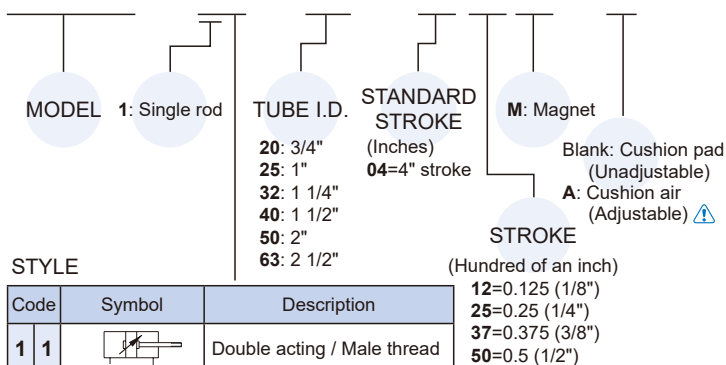

Caution

For (A) Cushion air (Adjustable)

- To adjust a cushion needle, please slowly turn the needle valve from the fully closed status to the required status which needs to be within 2.5 turns.
- If the needle valve loosen excessively, the buffer doesn't take effect and the lifetime of cylinder would be shortened.

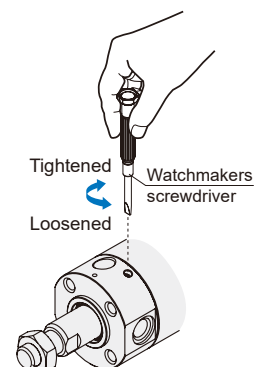





* Order example for special specification, refer to page 0-7.

* Order example for component parts and repair kits, refer to page 3-84.

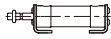
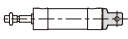
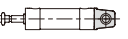
ROUND CYLINDER

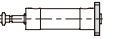
■ Mounting accessories

Accessories					
Code	LB (Purchase 2 pcs)	CA	CB	FAC	FBC
Mounting Tube I.D.					
20: 3/4"	LB-C2-20	CA-C2-20	CB-C2-20	FAC-C2-20	
25: 1"	LB-C2-25	CA-C2-25	CB-C2-25	FAC-C2-25	
32: 1 1/4"	LB-C2-32	CA-C2-32	CB-C2-32	FAC-C2-32	
40: 1 1/2"	LB-C2-40	CA-C2-40	CB-C2-40	FAC-C2-40	
50: 2"	LB-C2-50	CA-C2-50	CB-C2-50	FAC-C2-50	
63: 2 1/2"	LB-C2-63	CA-C2-63	CB-C2-63	FAC-C2-63	

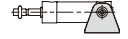
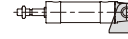
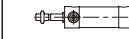
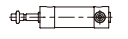
Accessories					
Code	SDB-R* ¹ (with TA)	SDB-H* ¹ (with TB)	CB+SDB+PIN* ¹ (with Pin)	TA (Front trunnion)	TB (Rear trunnion)
Mounting Tube I.D.					
20: 3/4"	SDB-C1-20		CB+SDB+PIN-C2-20	TA-C1-20	
25: 1"	SDB-C1-25		CB+SDB+PIN-C2-25	TA-C1-25	
32: 1 1/4"	SDB-C1-32		CB+SDB+PIN-C2-32	TA-C1-32	
40: 1 1/2"	SDB-C1-40		CB+SDB+PIN-C2-40	TA-C1-40	
50: 2"	SDB-C1-50		CB+SDB+PIN-C2-50	TA-C1-50	
63: 2 1/2"	SDB-C1-63		CB+SDB+PIN-C2-63	TA-C1-63	

1. Mounting procedures please refer to page 3-90.

■ Pin

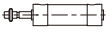
Rod nut	
Code	NUT
Mounting Tube I.D.	
20: 3/4"	NUT-1/4-28UNFx0.16Hx0.44B
25: 1"	NUT-5/16-24UNFx0.19Hx0.5B
32: 1 1/4"	NUT-7/16-20UNFx0.26Hx0.69B
40: 1 1/2"	
50: 2"	NUT-1/2-20UNFx0.32Hx0.75B
63: 2 1/2"	

Applicable CB accessories	
Code	PIN-CB-P (With snap ring)
Fig Tube I.D.	
20: 3/4"	PIN-C1-20-1-P
25: 1"	PIN-C1-25-1-P
32: 1 1/4"	PIN-C1-32-1-P
40: 1 1/2"	PIN-C1-40-1-P
50: 2"	PIN-C1-50-1-P
63: 2 1/2"	PIN-C1-63-1-P

Cushion pad Unadjustable

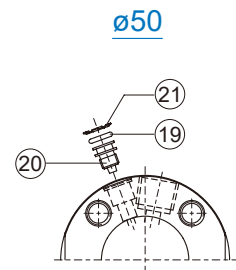
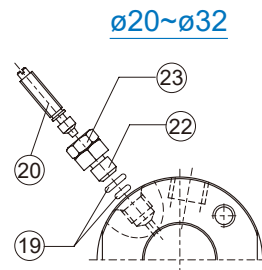
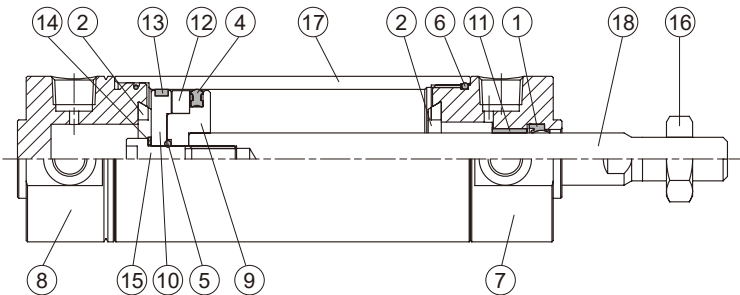

Cushion air Adjustable

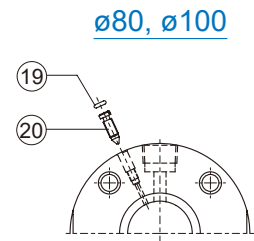
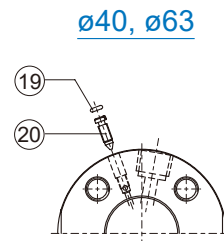
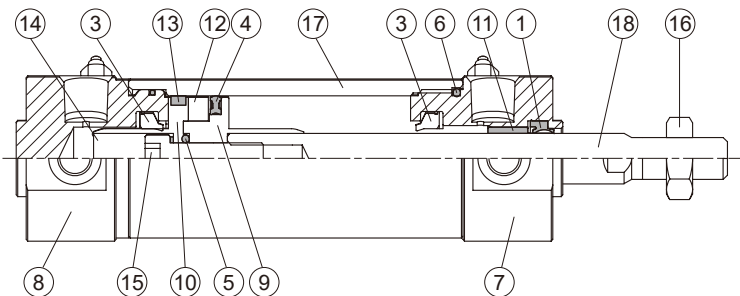

Material

A: Component parts, B: Repair kits

No.	Cushion		Part name	Material	Q'y	A	B	Note
	Pad	Air				(inclusion)		
1	●	●	Rod packing	NBR	1	●	●	
2	●	●	Cushion pad	NBR	2	●	●	
3	●	●	Cushion pad	NBR	2	●	●	
4	●	●	Piston packing	NBR	1	●	●	
5	●	●	O-ring	NBR	1	●	●	
6	●	●	O-ring	NBR	1 or 2	●	●	ø50~100 (Q'y=2)
7	●	●	Rod cover	Aluminum alloy	1	●		
8	●	●	Head cover	Aluminum alloy	1	●		
9	●	●	Piston-R	Aluminum alloy	1	●		
10	●	●	Piston-H	Aluminum alloy	1	●		
11	●	●	Bush	Bearing alloy	1	●		
12	●	●	Magnet ring	Magnet material	1	◎		◎ Option
			Spacer ring	Aluminum alloy	1	●		for ø20~ø32
13	●	●	Wear ring	Resin	1	●		
14	●	●	Washer	Carbon steel	1	●		ø20 without
15	●	●	Piston bolt	Carbon steel	1	●		
16	●	●	Nut	Carbon steel	1	●		
17	●	●	Cylinder tube	Aluminum alloy	1			
18	●	●	Piston rod	Carbon steel	1			ø20~25 stainless steel
19	●	●	O-ring	NBR	4 or 2			ø40~80 (Q'y=2)
20	●	●	Needle valve	Stainless steel	2			*1
21	●	●	Needle valve packing	Carbon steel	2			only for ø50
22	●	●	Needle valve fixed nut	Stainless steel	2			only for ø20~32
23	●	●	Hex nut	Carbon steel	2			only for ø20~32

*1. ø50: Copper, ø63~100: Carbon steel

Order example of component parts

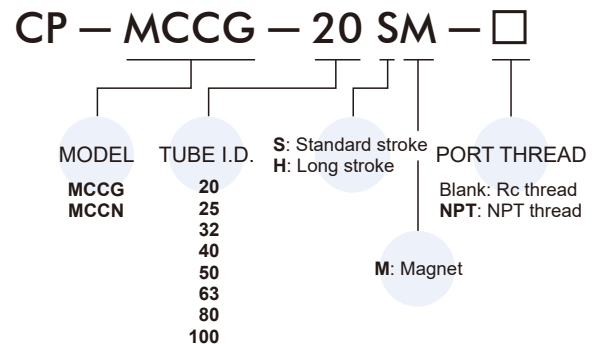

* MCCN only be used for NPT.

* Order example for G thread, please consult us.

Order example of repair kits

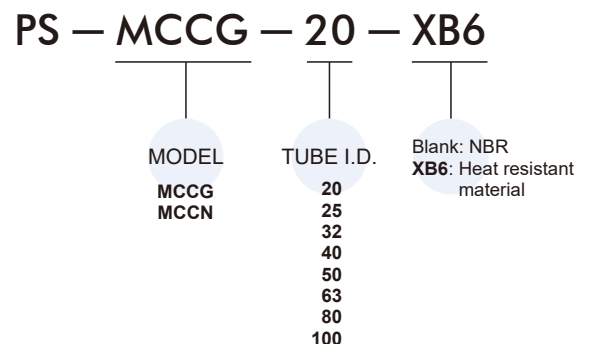

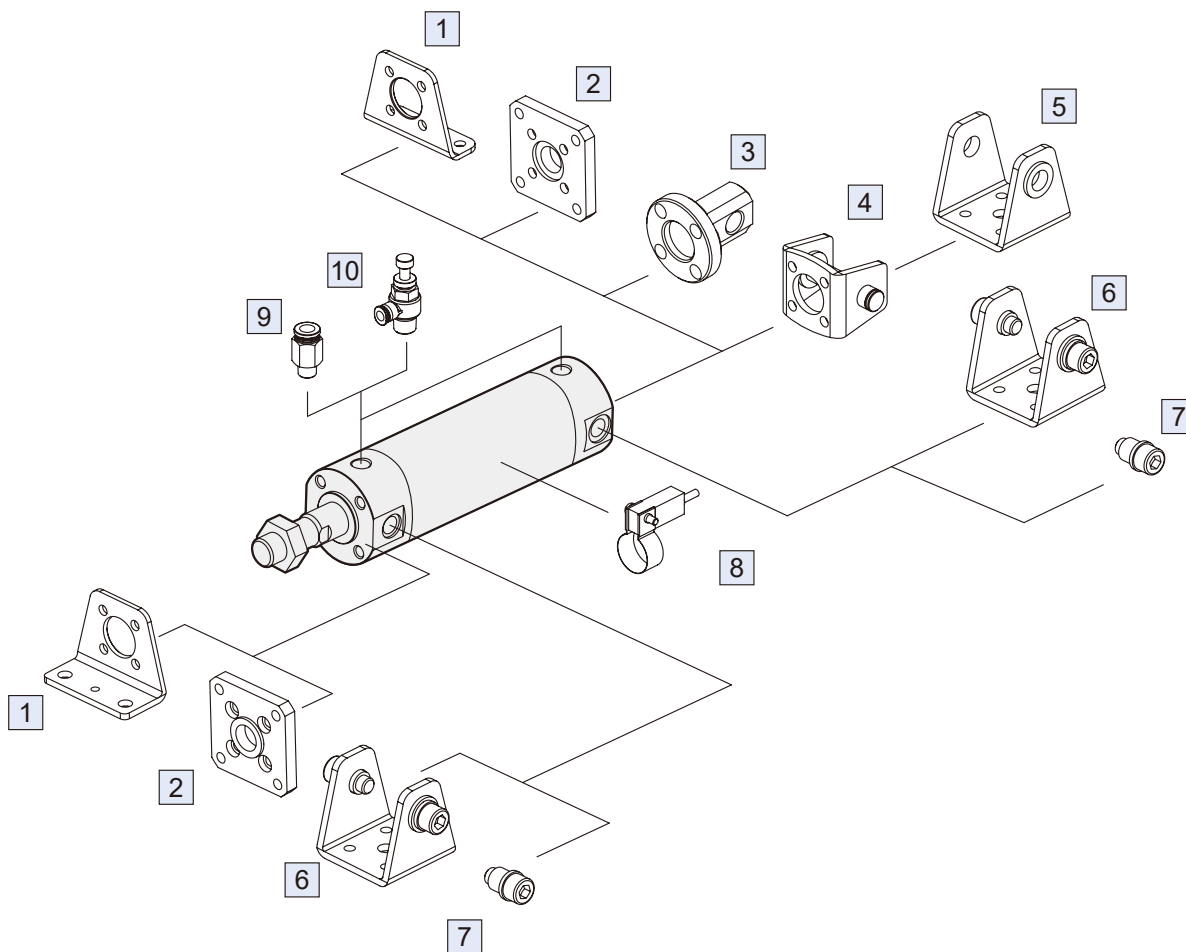

No.	Accessories	Material	Page
1	Mounting accessories LB	Carbon steel	3-95
2	Mounting accessories FAC/FBC	Carbon steel	3-95
3	Mounting accessories CA	Carbon steel	3-96
4	Mounting accessories CB+PIN	Carbon steel	3-96, 98, 90
5	Mounting accessories SDB	Carbon steel	3-97, 90
6	Mounting accessories SDB-R/H	Carbon steel	3-97, 90
7	Mounting accessories TA/TB	Carbon steel	3-98, 90
8	Sensor switch RCM+BMG**	—	8-16
9	Fitting PC (PISCO)	—	8-3 (Vol.1)
10	Speed controller JSC (PISCO)	—	8-15 (Vol.1)

ROUND CYLINDER

mindman

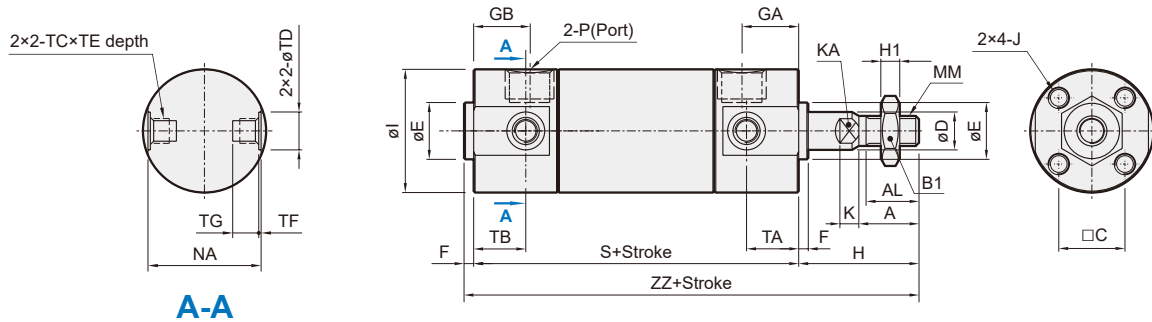

A-A

Cushion air (Adjustable)

A

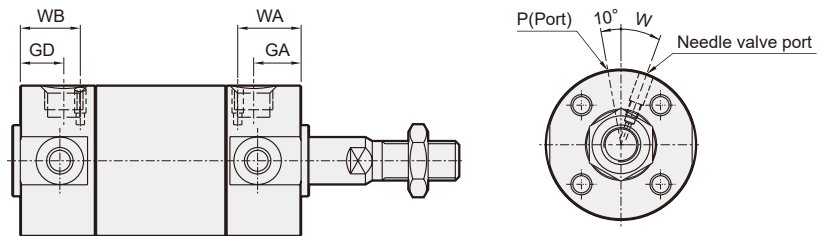

Unit: inch

Code Tube I.D.	Standard stroke range	Long stroke range	A	AL	B1	C	D	E	F	GA	GB	GD	H	H1	I	J	K
20	~ 8	8.01 ~ 14	0.50	0.44	0.44	0.55	0.315	0.472 ^{+0/-0.002}	0.08	0.47	0.47 (0.47)	0.47 (0.47)	1	0.16	1.02	#8-32×0.28 dp	0.157
25	~12	12.01 ~ 16	0.50	0.44	0.50	0.65	0.394	0.551 ^{+0/-0.002}	0.08	0.47	0.47 (0.47)	0.47 (0.47)	1.12	0.19	1.22	#10-32×0.30 dp	0.197
32	~12	12.01 ~ 18	0.75	0.69	0.69	0.79	0.472	0.709 ^{+0/-0.002}	0.08	0.47	0.43 (0.47)	0.43 (0.47)	1.63	0.26	1.50	#10-32×0.30 dp	0.217
40	~12	12.01 ~ 32	0.75	0.69	0.69	1.02	0.630	0.984 ^{+0/-0.002}	0.08	0.51	0.47 (0.51)	0.39 (0.51)	1.63	0.26	1.85	1/4-28×0.47 dp	0.3
50	~12	12.01 ~ 48	0.88	0.84	0.75	1.26	0.787	1.181 ^{+0/-0.002}	0.08	0.55	0.51 (0.51)	0.47 (0.55)	2.07	0.32	2.28	5/16-24×0.63 dp	0.276
63	~12	12.01 ~ 27.5	0.88	0.84	0.75	1.50	0.787	1.260 ^{+0/-0.002}	0.08	0.55	0.51 (0.51)	0.47 (0.55)	2.07	0.32	2.83	3/8-24×0.63 dp	0.276

Code Tube I.D.	KA	MM	NA	P	S	TA	TB	TC	TD _{H9}	TE	TF	TG	W	WA	WB	ZZ
20	0.24	1/4-28 UNF	0.94	NPT1/8	2.72 (3.03)	0.43	0.43 (0.43)	M5×0.8	0.315	0.157	0.020	0.217	40°	0.551	0.551 (0.551)	3.80 (4.11)
25	0.31	5/16-24 UNF	1.14	NPT1/8	2.72 (3.03)	0.43	0.43 (0.43)	M6×0.75	0.394	0.197	0.039	0.256	40°	0.551	0.511 (0.511)	3.92 (4.23)
32	0.39	7/16-20 UNF	1.42	NPT1/8	2.80 (3.11)	0.43	0.39 (0.43)	M8×1.0	0.472	0.217	0.049	0.295	30°	0.551	0.511 (0.511)	4.51 (4.82)
40	0.55	7/16-20 UNF	1.73	NPT1/8	3.07 (3.43)	0.47	0.39 (0.47)	M10×1.25	0.551	0.236	0.049	0.315	20°	0.629	0.590 (0.629)	4.78 (5.14)
50	0.71	1/2-20 UNF	2.17	NPT1/4	3.54 (4.02)	0.51	0.47 (0.51)	M12×1.25	0.630	0.295	0.079	0.394	20°	0.629	0.629 (0.629)	5.69 (6.17)
63	0.71	1/2-20 UNF	2.72	NPT1/4	3.54 (4.02)	0.51	0.47 (0.51)	M14×1.5	0.709	0.453	0.118	0.571	20°	0.708	0.708 (0.708)	5.69 (6.17)

(): Dimension for long stroke.

Installation of sensor switch

Sensor switch: RCM

Sensor switch band: BMG**

Unit: inch

Code Tube I.D.	A	B	C	D	E
20	0.9449	1.4764	0.2756	0.6299	1.1024
25	1.0433	1.6732	0.2756	0.6299	1.1024
32	1.2008	1.9882	0.2756	0.6299	1.1024
40	1.3780	2.3425	0.2756	0.6299	1.1024
50	1.5945	2.7756	0.2756	0.6299	1.1024
63	1.8701	3.3268	0.2756	0.6299	1.1024

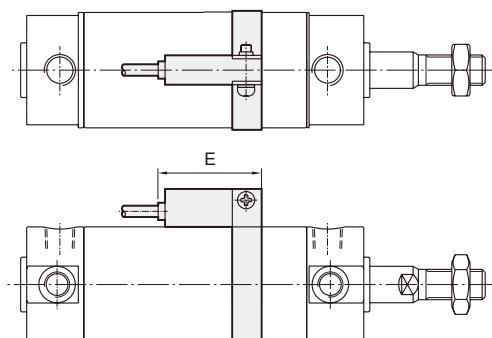
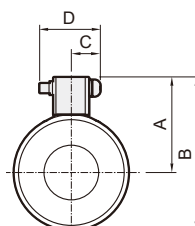

LB

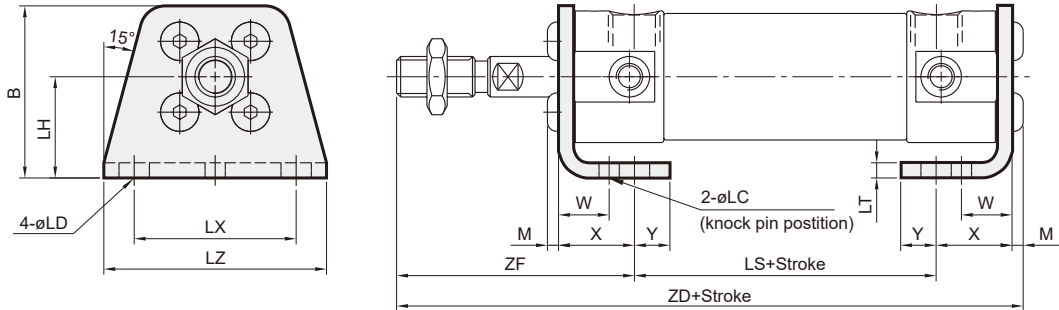

Unit: inch

Code Tube I.D.	B	LC	LD	LH	LS	LT	LX	LZ	M	W	X	Y	ZD	ZF
20	1.34	0.16	0.24	0.79	1.78 (2.09)	0.12	1.26	1.73	0.09	0.39	0.59	0.28	3.93 (4.24)	1.47
25	1.52	0.16	0.24	0.87	1.78 (2.09)	0.12	1.42	1.93	0.11	0.39	0.59	0.28	4.07 (4.38)	1.59
32	1.77	0.16	0.26	0.98	1.78 (2.09)	0.12	1.73	2.28	0.11	0.39	0.63	0.31	4.66 (4.97)	2.14
40	2.15	0.16	0.26	1.18	2.01 (2.37)	0.12	2.13	2.80	0.13	0.39	0.65	0.33	4.95 (5.31)	2.16
50	2.78	0.20	0.35	1.57	2.16 (2.64)	0.18	2.60	3.39	0.17	0.69	0.87	0.43	5.96 (6.44)	2.76
63	3.25	0.20	0.43	1.77	2.16 (2.64)	0.18	3.23	4.17	0.22	0.69	0.87	0.51	6.01 (6.49)	2.76

(): Dimension for long stroke.

FAC

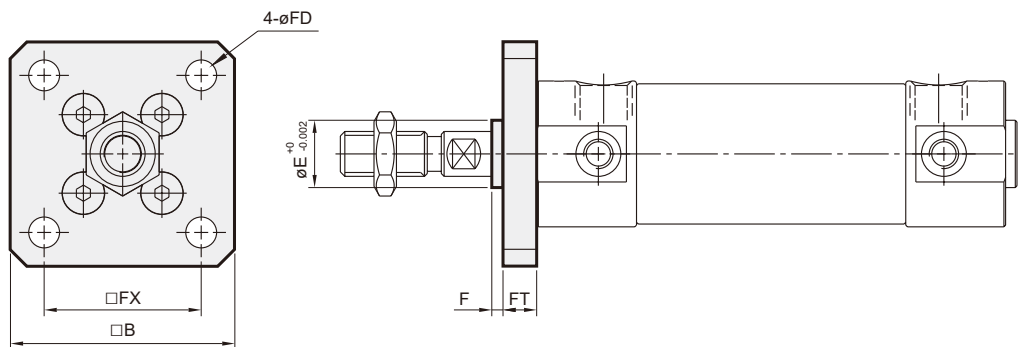

FBC

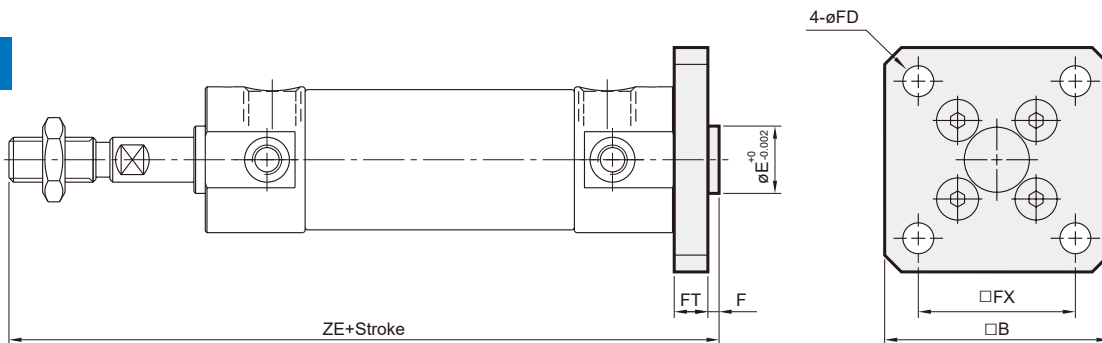

Unit: inch

Code Tube I.D.	B	E	F	FX	FD	FT	ZE
20	1.57	0.472	0.08	1.10	0.22	0.24	4.04 (4.35)
25	1.73	0.551	0.08	1.26	0.22	0.28	4.20 (4.51)
32	2.09	0.709	0.08	1.50	0.26	0.28	4.79 (5.10)
40	2.40	0.984	0.08	1.81	0.26	0.31	5.09 (5.45)
50	2.99	1.181	0.08	2.28	0.35	0.35	6.04 (6.52)
63	3.62	1.260	0.08	2.76	0.43	0.35	6.04 (6.52)

(): Dimension for long stroke.

ROUND CYLINDER

CA

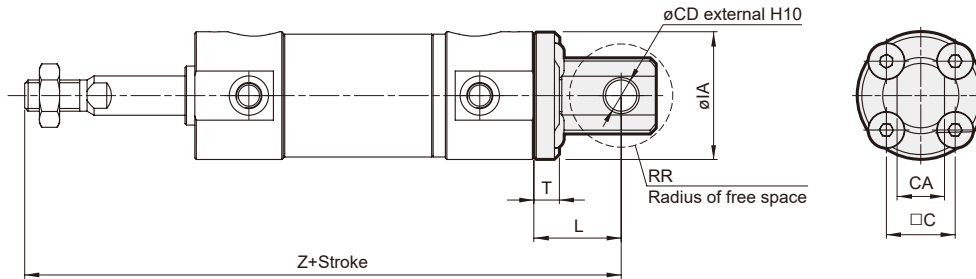

Unit: inch

Code Tube I.D.	C	CA	CD	IA	L	RR	T	Z
20	0.55	0.38	0.25	1.02	0.70	0.42	0.20	4.42(4.73)
25	0.65	0.38	0.25	1.22	0.68	0.75	0.21	4.52(4.83)
32	0.79	0.5	0.25	1.49	1.07	0.60	0.47	5.50(5.81)
40	1.02	0.62	0.375	1.85	0.88	0.65	0.25	5.58(5.94)
50	1.26	0.75	0.375	2.28	0.91	0.38	0.29	6.52(7)
63	1.5	0.75	0.375	2.83	0.91	0.38	0.29	6.52(7)

(): Dimension for long stroke.

CB SDB+Pin (Extra purchase)

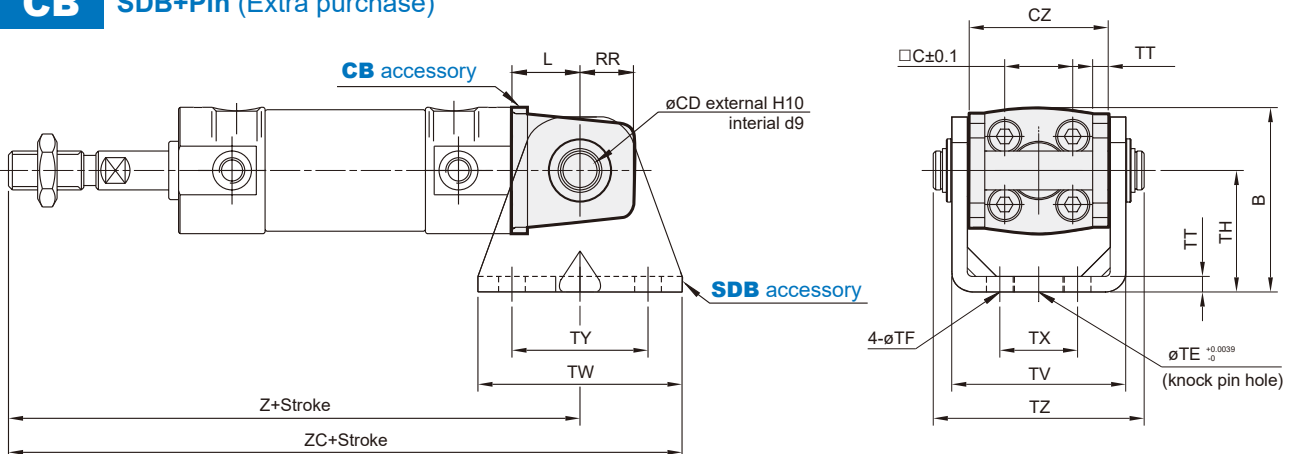

Unit: inch

Code Tube I.D.	B	CD	CZ	L	RR	TE	TF	TH	TT	TV	TW	TX	TY	TZ	Z	ZC
20	1.50	0.315	1.14	0.55	0.43	0.394	0.22	0.98	0.13	1.41	1.65	0.63	1.10	1.71	4.27 (4.58)	5.10 (5.41)
25	1.79	0.394	1.30	0.63	0.51	0.394	0.22	1.18	0.13	1.57	1.65	0.79	1.10	1.89	4.47 (4.78)	5.30 (5.61)
32	2.13	0.472	1.57	0.79	0.59	0.394	0.26	1.38	0.18	1.94	1.89	0.87	1.10	2.34	5.22 (5.53)	6.16 (6.47)
40	2.50	0.551	1.93	0.87	0.71	0.394	0.26	1.57	0.18	2.30	2.20	1.18	1.18	2.81	5.57 (5.93)	6.67 (7.03)
50	3.11	0.630	2.36	0.98	0.79	0.787	0.35	1.97	0.24	2.85	2.52	1.42	1.42	3.39	6.59 (7.07)	7.85 (8.33)
63	3.78	0.709	2.91	1.18	0.87	0.787	0.43	2.36	0.31	3.56	2.91	1.81	1.81	4.15	6.79 (7.27)	8.25 (8.73)

(): Dimension for long stroke.

SDB TA/TB (Extra purchase)

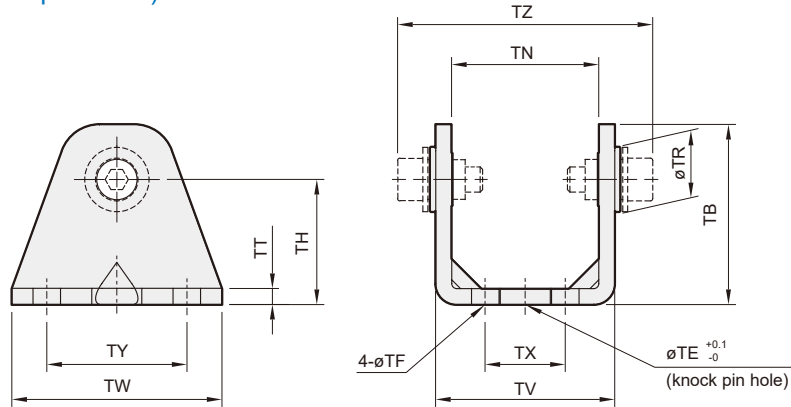

SDB-R

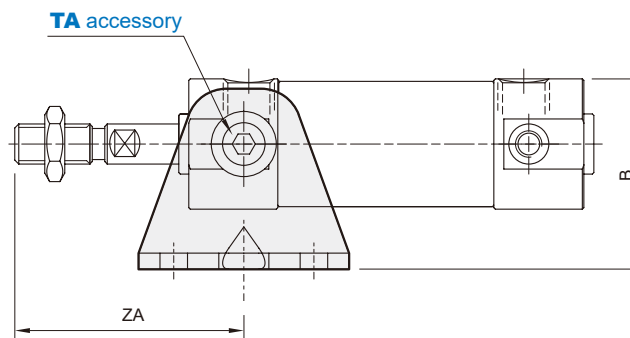

SDB-H

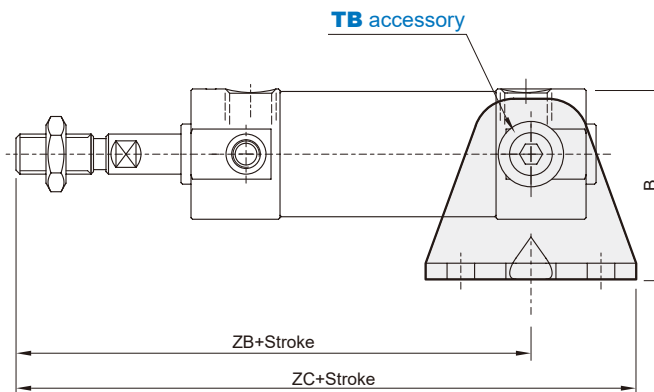

Unit: inch

Code Tube I.D.	B	TB	TE	TF	TH	TN	TR	TT	TV	TW	TX	TY	TZ	ZA	ZB	ZC	Applicable pin O.D.
20	1.50	1.42	0.394	0.22	0.98	1.15	0.55	0.13	1.41	1.65	0.63	1.10	2.00	1.43	3.29(3.6)	3.80(4.11)	0.315 -0.0016 -0.0030
25	1.79	1.69	0.394	0.22	1.18	1.30	0.63	0.13	1.57	1.65	0.79	1.10	2.29	1.55	3.41(3.72)	3.92(4.23)	0.394 -0.0016 -0.0030
32	2.13	1.97	0.394	0.26	1.38	1.59	0.71	0.18	1.94	1.89	0.87	1.10	2.81	2.06	4.04(4.31)	4.51(4.82)	0.472 -0.0020 -0.0037
40	2.50	2.28	0.394	0.26	1.57	1.94	0.87	0.18	2.30	2.20	1.18	1.18	3.48	2.10	4.31(4.59)	4.78(5.14)	0.551 -0.0020 -0.0037
50	3.11	2.76	0.787	0.35	1.97	2.38	0.98	0.24	2.85	2.52	1.42	1.42	4.29	2.58	5.14(5.58)	5.69(6.17)	0.630 -0.0020 -0.0037
63	3.78	3.23	0.787	0.43	2.36	2.94	1.06	0.31	3.56	2.91	1.81	1.81	5.15	2.58	5.14(5.58)	5.69(6.17)	0.709 -0.0020 -0.0037

(): Dimension for long stroke.

TA Front trunnion

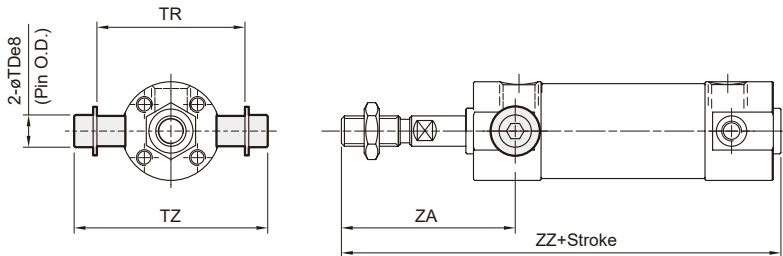

Unit: inch

Code Tube I.D.	TB	TDe8	TR	TZ
20	0.43(0.43)	0.315	1.54	2.00
25	0.43(0.43)	0.394	1.69	2.29
32	0.39(0.43)	0.472	2.11	2.81
40	0.39(0.47)	0.551	2.54	3.48
50	0.47(0.51)	0.630	3.15	4.29
63	0.47(0.51)	0.709	3.86	5.15

(): Dimension for long stroke.

TB Rear trunnion

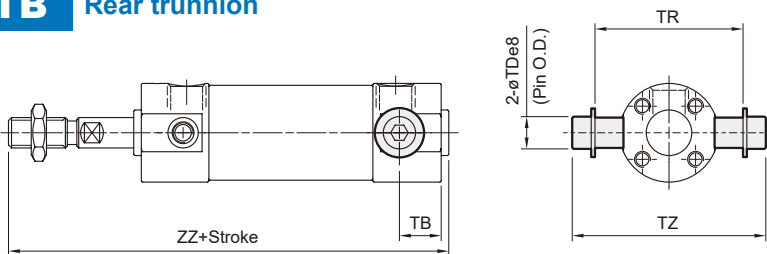

Unit: inch

Code Tube I.D.	ZA	ZB	ZZ
20	1.43	3.29 (3.60)	3.80 (4.11)
25	1.55	3.41 (3.72)	3.92 (4.23)
32	2.06	4.04 (4.31)	4.51 (4.82)
40	2.10	4.31 (4.59)	4.78 (5.14)
50	2.58	5.14 (5.58)	5.69 (6.17)
63	2.58	5.14 (5.58)	5.69 (6.17)

(): Dimension for long stroke.

PIN

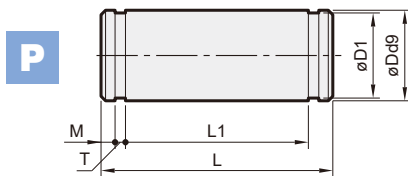

for CB

Unit: inch

Code Tube I.D.	Dd9	D1	L	L1	M	T	Snap ring
20	0.315 ^{-0.0016} _{-0.0030}	0.30	1.71	1.52	0.06	0.04	STW-8
25	0.394 ^{-0.0016} _{-0.0030}	0.38	1.89	1.68	0.06	0.05	STW-10
32	0.472 ^{-0.0020} _{-0.0037}	0.45	2.34	2.13	0.06	0.05	STW-12
40	0.551 ^{-0.0020} _{-0.0037}	0.53	2.81	2.56	0.08	0.05	STW-14
50	0.630 ^{-0.0020} _{-0.0037}	0.60	3.39	3.13	0.08	0.05	STW-16
63	0.709 ^{-0.0020} _{-0.0037}	0.67	4.15	3.85	0.10	0.05	STW-18

ROUND CYLINDER

TA Front trunnion

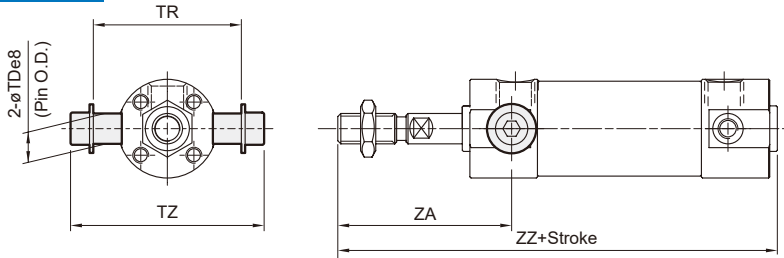

TB Rear trunnion

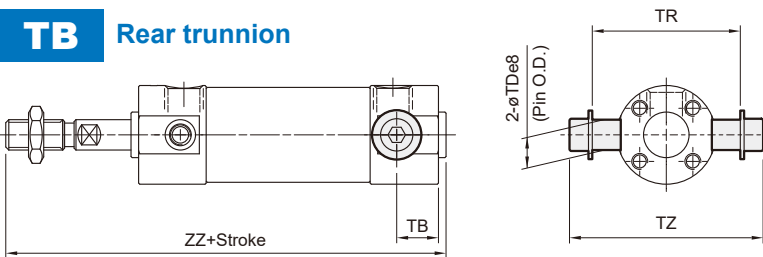

Code Tube I.D.	TB	TDe8	TR	TZ	ZA	ZZ
20	11(11)	8 ^{+0.025} _{-0.047}	39	51	46	106 (114)
25	11(11)	10 ^{+0.025} _{-0.047}	43	58.2	51	111 (119)
32	10(11)	12 ^{+0.032} _{-0.059}	53.5	71.5	51	113 (121)
40	10(12)	14 ^{+0.032} _{-0.059}	64.5	88.5	62	130 (139)
50	12(13)	16 ^{+0.032} _{-0.059}	80	109	71	150 (162)
63	12(13)	18 ^{+0.032} _{-0.059}	98	131	71	150 (162)

(): Dimension for long stroke.

MCCG / MCCN

SDB-R(H) / TA / TB Mounting procedures

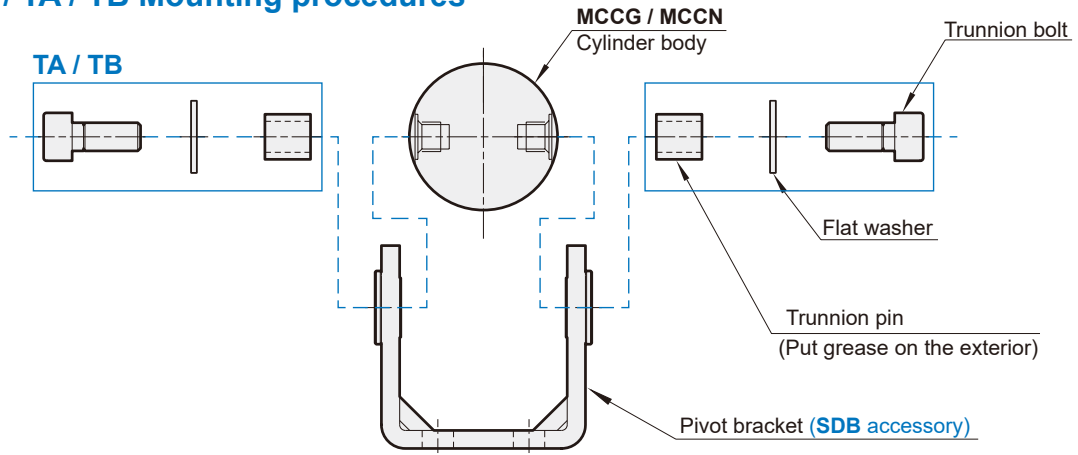

CB+PIN+SDB Mounting procedures

